

**DIVISION II**  
**CONSTRUCTION AND MATERIAL SPECIFICATIONS**  
**SECTION 2300 INCIDENTAL CONSTRUCTION**

APPROVED AND ADOPTED THIS 15TH DAY OF JULY 2009

**KANSAS CITY METROPOLITAN CHAPTER**  
**OF THE AMERICAN PUBLIC WORKS ASSOCIATION**

**TABLE OF CONTENTS**

<b>SECTION 2301 STANDARD SIDEWALKS, SIDEWALK RAMPS, DRIVEWAYS, AND BICYCLE/PEDESTRIAN PATHS. ....</b>	<b>1</b>
2301.1 Referenced Standards .....	1
2301.2 Summary .....	1
2301.3 Materials .....	1
2301.4 Construction Details .....	1
2301.5 Joints .....	2
2301.6 Concrete Work .....	3
2301.7 Backfill .....	4
2301.8 Joint Sealing and Clean-Up .....	4
2301.9 Detectable Warnings .....	4
2301.10 Method of Measurement .....	4
2301.11 Basis of Payment .....	5
<b>SECTION 2302 ASPHALT SIDEWALKS, DRIVEWAYS, AND BICYCLE/PEDESTRIAN PATHS .....</b>	<b>5</b>
2302.1 Summary .....	5
2302.2 Asphalt Sidewalks .....	5
2302.3 Asphalt Driveways .....	5
2302.4 Bicycle/Pedestrian Paths .....	5
2302.5 Method of Measurement .....	5
2302.6 Basis of Payment .....	6
<b>SECTION 2303 ROCK BLANKET .....</b>	<b>6</b>
2303.1 Summary .....	6
2303.2 Materials .....	6
2303.3 Construction Requirements .....	6
2303.4 Method of Measurement .....	6
2303.5 Basis of Payment .....	7
<b>SECTION 2304 CONCRETE PAVER STONES (For Median Treatment) .....</b>	<b>7</b>
2304.1 Referenced Standards .....	7
2304.2 Summary .....	7
2304.3 Materials .....	7
2304.4 Construction Details .....	9
2304.5 Method of Measurement .....	9
2304.6 Basis of Payment .....	9

<b>SECTION 2305 MAINTENANCE OF TRAFFIC .....</b>	<b>10</b>
2305.1 Referenced Standards .....	10
2305.2 Summary .....	10
2305.3 General .....	10
2305.4 Traffic Maintenance and Warning Devices .....	10
2305.5 Flashers and Other Traffic Control Devices .....	10
2305.6 Method of Measurement .....	10
2305.7 Basis of Payment .....	10
<b>SECTION 2306 PAVEMENT MARKINGS .....</b>	<b>10</b>
2306.1 Referenced Standards .....	10
2306.2 Summary .....	12
2306.3 General .....	12
2306.4 Striping Applicability Chart .....	13
2306.5 Symbol Applicability Charts .....	13
2306.6 Prequalification: .....	14
2306.7 Materials .....	14
2306.8 Method of Installation .....	27
2306.9 Method of Removal .....	33
2306.10 Performance Measures .....	33
2306.11 Method of Measurement .....	40
2306.12 Basis of Payment: Pavement Markings will be paid for by one of the following: .....	40
<b>SECTION 2307 FENCING .....</b>	<b>40</b>
2307.1 Summary .....	40
2307.2 Referenced Standards .....	40
2307.3 Materials: .....	41
2307.4 Construction Details: .....	41
2307.5 Measurement and Payment .....	41
<b>SECTION 2308 STEEL BEAM GUARDRAIL .....</b>	<b>42</b>
2308.1 Scope .....	42
2308.2 Erection: .....	42
2308.3 Measurement and Payment .....	42
<b>SECTION 2309 MEASUREMENTS AND PAYMENT .....</b>	<b>43</b>
2309.1 Summary .....	43
2309.2 General .....	43
2309.3 Measurement .....	43
2309.4 Measurement and Payment Summary Table .....	43

**DIVISION II**  
**CONSTRUCTION AND MATERIAL SPECIFICATIONS**  
**SECTION 2300 INCIDENTAL CONSTRUCTION**

**SECTION 2301 STANDARD SIDEWALKS, SIDEWALK RAMPS, DRIVEWAYS, AND BICYCLE/PEDESTRIAN PATHS.**

**2301.1 Referenced Standards**

The following standards are referenced directly in this section. The latest version of these standards shall be used.

**ADA Accessibility Guidelines for Buildings and Facilities (ADAAG)**

Section 4.7 – Curb Ramps

**American Concrete Institute (ACI 301)**

ACI 305R = Cold Weather Concrete

ACI 306R = Hot Weather Concrete

**American Society of Test Methods (ASTM)**

D1751 – Standard Specification for Preformed Expansion Joint Filler for Concrete Paving and Structural Construction (Nonextruding and Resilient Bituminous Types)

D1752 – Standard Specification for Preformed Sponge Rubber and Cork Expansion Joint Fillers for Concrete Paving and Structural Construction

D2805 – Standard Test Method for Hiding Power of Paints by Reflectometry

**Midwest Concrete Industry Board (MCIB)**

Sections 1, 2, & 3 (Use Latest Revisions Adopted)

Mix No. WA610–1–4

See MCIB website for more information ([www.mcibconcrete.org](http://www.mcibconcrete.org))

**2301.2 Summary**

This section includes the construction or reconstruction of sidewalks, sidewalk ramps driveways, and bicycle/pedestrian paths.

**2301.3 Materials**

All materials in this section shall conform to the requirements of Section 2208.2.

- A. Concrete Mix: Concrete shall conform to the requirements of MCIB Mix No. WA610–1–4. When the ambient air temperature is 90 degrees F (32 degrees C) or higher, a retarder will be used in all concrete mixes.
- B. Reinforcement: Reinforcement is not required unless shown on the plans.

**2301.4 Construction Details**

The sidewalks, sidewalk ramps, driveways or bicycle/pedestrian paths shall be constructed or reconstructed to the configuration, and to the lines and grades shown by the plans. Generally sidewalks, sidewalk ramps, driveways, and

bicycle/pedestrian paths should be constructed after the curbing. Sidewalk ramp construction shall comply fully with all requirements for sidewalks in this section and shall comply with the requirements of ADAAG Section 4.7.

- A. **Removal:** Existing sidewalks, sidewalk ramps, driveways, or bicycle/pedestrian paths shall be totally removed to the nearest contraction or isolation joint, unless otherwise specified by the Engineer. The section shall be sawed full depth.
- B. **Grading and Subgrade Preparation:** All excavation or embankment required in the grading or subgrade preparation shall be as defined in the Sections 2100 and 2201 entitled "Grading and Site Preparation" and "Subgrade Preparation," except as follows:
  - 1. The top 6 inches (150 mm) of the subgrade shall be compacted to obtain a density of 95 percent of maximum in conformance with Section 2201.3B.
  - 2. If during reconstruction operations additional fill material is needed beneath sidewalks or driveways it shall be of crushed stone conforming to Section 2202.2, compacted in conformance with Section 2202.3.
- C. **Forms:** All forms shall be in good condition, clean, and free from imperfections. Each form shall not vary more than 1/4 inch (0.64 cm) in horizontal or vertical alignment for each 10 feet (3.05 m) in length.
  - 1. **Material and Size:** Forms shall be made of metal unless otherwise approved by the Engineer and shall have a height equal to or greater than the depth of the sidewalk, driveway, or bicycle/pedestrian path section.
  - 2. **Strength:** Forms shall be of such cross-section and strength, and so secured as to resist the pressure of the concrete when struck off, vibrated, and finished, and the impact and vibration of any equipment which they may support.
  - 3. **Installation:** The forms shall be set true to line and grade, supported through their length and joined neatly in such a manner that the joints are free from movement in any direction.
  - 4. **Preparation:** Forms shall be cleaned and lubricated prior to each use and shall be so designed to permit their removal without damage to the new concrete.
- D. **Slip-Form Machine:** A slip-form machine may be used in lieu of forms. The machine must be equipped with mechanical internal vibrators and be capable of placing concrete to the correct cross section, line and grade within the allowable tolerances.

### 2301.5 Joints

Unless directed by the Engineer the joints shall be formed at right angles to the alignment of the sidewalk, driveway, or bicycle/pedestrian path and to the configuration specified by the plans or standards.

- A. **Joint Patterns**
  - 1. **Sidewalks:** Sidewalk surfaces shall be marked with a transverse joint spaced at a distance equal to the width of the sidewalk. Edger tool marks shall remain showing unless the sidewalk is slip-formed and subsequently sawed. Curb joints should align with sidewalk joints where they abut.
  - 2. **Driveways and bicycle/pedestrian paths:** In general, no driveway slab dimension shall exceed 10 feet (3.05 m), although widths no more than 24 times the slab thickness will be permitted to match existing joint patterns.
- B. **Isolation joints:** Isolation joints shall be placed where directed by the plans or Engineer.
  - 1. **General:** The preformed isolation joint material shall be left 1/2 inch (13 mm) below the surface, or a suitable tear strip will be provided to allow for the application of the joint sealer.

2. **Material:** Isolation joints shall be formed by a 1 piece; 1/2 inch (13 mm) thick non-extruding preformed joint filler cut to the configuration of the abutting section. The filler material shall be full depth, and shall conform to ASTM D1751 or D1752. D1752 material shall be used against curved surfaces, around utility boxes or poles, or against other irregular surfaces.
  3. **Stability:** Isolation joints shall be secured in a manner so they will not be disturbed by depositing and consolidating the concrete.
  4. **Edging:** The newly poured edges of these joints shall be rounded with an edging tool of 1/4inch (6 mm) radius.
- C. Contraction Joints:** Contraction joints for 4 inch (102 mm) slabs shall be 1 inch (25 mm) deep by 1/8 inch (3 mm) wide with 1/4 inch (6 mm) radii rounded edges. For slabs thicker than 4", Contraction joints shall be 1/3" thickness of the slab by 1/8 inch wide.
1. **Edging:** Edger marks shall remain showing unless the sidewalk, driveway or bicycle/pedestrian path is slip formed and subsequently sawed.
  2. **Slip forming:** Contraction joints may be sawed 1/8 inch (3 mm) wide by 1/3<sup>rd</sup> the thickness of the slab.
  3. **Joint Sealer:** joint sealer is not required.

#### 2301.6 Concrete Work

Concrete work shall be placed in accordance with the requirements of ACI 301.

- A. Concrete Placement:** Deposit and consolidate concrete as close to the final position as possible, beginning at one corner of the forms. Perform necessary hand spreading with shovels or come-alongs, not with rakes or vibrators. Do not walk in the fresh concrete with boots or shoes coated with earth or foreign substances. When concrete is placed on a sloped surface, begin concrete placement at the lowest area.
- B. Finishing**
  1. Strike off the concrete with a vibratory screed or a hand strike-off method when adequate consolidation is attained. Immediately after strike-off, the concrete may be bull floated to remove any high or low spots. Minimize the use of the bull float.
  2. Do not finish concrete with water standing on the surface. All edges of the slab shall be carefully finished with a 1/4 inch (6 mm) radius edger.
  3. After finishing, the surface of the concrete shall be broomed with a fine clean broom to provide an antiskid surface, and the edges and joints retooled unless slip formed.
  4. In all cases the finished sidewalk, driveway, or bicycle/pedestrian path shall have a true surface, free from sags, twists, or warps, and shall have a uniform color and appearance.
- C. Curing:** As soon as practical after the concrete is finished it shall be cured with one of the acceptable liquid curing membranes applied according to manufacturer's directions. A visual pigmented cure is recommended.

If forms are removed within a period of 72 hours of placement those formed surfaces shall also be cured.

Wet burlap, cotton mats, waterproof paper, polyethylene sheeting or earth backfill shall not be acceptable as curing methods.

- D. Protection:** The Contractor shall protect the concrete work against damage or defacement of any kind until it has been accepted by the City. Concrete which is damaged or defaced shall be removed and replaced or repaired to the satisfaction of the Engineer, at the expense of the Contractor.

- E. **Temperature Limitations:** Concrete shall be placed in accordance with requirements of ACI 301, ACI 305R, and ACI 306R.

**2301.7 Backfill**

- A. A minimum of 24 hours shall elapse before forms are removed and 5 days shall elapse or the concrete must have attained 75% of its 28 day compressive strength before pavement is backfilled unless otherwise approved by the Engineer.
- B. Backfill shall be accomplished in accordance with Sections 2100 and 2201 entitled "Grading and Site Preparation" and "Subgrade Preparation."
- C. The Contractor shall be responsible for the repair of any street pavement disturbed by the construction.

**2301.8 Joint Sealing and Clean-Up**

- A. All isolation joints shall be sealed with an approved joint sealer in Section 2208.2 and applied in accordance with Section 2208.7 within 7 days of the placement of the concrete.
- B. The Contractor shall be responsible for the removal of excess dirt, rock, broken concrete, splatters and overspray from the construction area within 10 days unless otherwise directed by the Engineer.
- C. **Surface Tolerances:** Sidewalks, driveways, or bicycle/pedestrian paths shall have a surface tolerance of 1/4 inch (6 mm) in 10 feet (3.05 m) when checked with a 10 foot (3.05m) straightedge. Vertical deflections at sidewalk joints shall not exceed 1/4 inch (6 mm).

**2301.9 Detectable Warnings**

Detectable warnings are required standardized surface features built in or applied to walking surfaces on sidewalks or ramps to warn visually impaired people of hazards on a circulation path. Those hazards include, but are not limited to interfaces between sidewalks and areas where moving vehicles may be present.

- A. **Dimensions:** Detectable warnings shall consist of raised truncated domes with a 0.9 in (23 mm) nominal diameter, a nominal 0.2 in (5mm) height, and a nominal center to center spacing of 2.35 in (60 mm). They shall extend across the full walking surface of the walk or ramp, and shall be 2 feet (0.6 m) long in the direction of pedestrian travel.
- B. **Contrast:** Detectable warnings shall contrast visually with adjoining surfaces, either light-on-dark or dark-on-light. The material used to provide contrast should contrast by at least 70%. Contrast in percent is determined by:

$$\text{Contrast} = [(B_1 - B_2) / B_1] \times 100$$

Where:

B<sub>1</sub>=light reflectance value (LRV) of the lighter area

B<sub>2</sub>=light reflectance value (LRV) of the darker area

Light Reflectance Value shall be determined by ASTM D2805 for painted surfaces or by visual comparison to paint chips with LRVs determined by ASTM D2805 for non-painted surfaces. Note that in any application both white and black are never absolute: thus B<sub>1</sub> is always less than 100, and B<sub>2</sub> is always greater than 0.

- C. **Material:** The material used to provide contrast shall be an integral part of the walking surface.

**2301.10 Method of Measurement**

- A. **Sidewalks:** Sidewalks will be measured per square foot (square meter or tenth part thereof).
- B. **Sidewalk Ramps:** Sidewalk ramps including detectable warning will be measured by one of the following:

1. Per square foot (square meter or tenth part thereof). Street curbing adjoining sidewalk ramps will be measured in accordance with Section 2209.9 and paid for separately.
  2. Per each
- C. Driveways:** Driveways will be measured per square foot (square meter or tenth part thereof).
- D. Bicycle Pedestrian Paths:** Bicycle/Pedestrian paths will be measured per square foot (square meter or tenth part thereof).

#### **2301.11 Basis of Payment**

All items in this section will be paid for by the contract unit bid price.

## **SECTION 2302 ASPHALT SIDEWALKS, DRIVEWAYS, AND BICYCLE/PEDESTRIAN PATHS**

### **2302.1 Summary**

This section governs the placement of asphalt sidewalks, driveways, and bicycle/pedestrian paths

### **2302.2 Asphalt Sidewalks**

Asphalt shall not be used in the construction of any approved permanent sidewalk. Asphalt may be used as material for temporary sidewalks if approved in advance by the Engineer.

### **2302.3 Asphalt Driveways**

Asphalt driveways may be constructed with prior approval of the Engineer in accordance with the provisions of Section 2201 and Section 2205 "Asphalt Paving" and Section 2209 "Curbing" as applicable. The sidewalks, sidewalk ramps, driveways or bicycle/pedestrian paths shall be constructed or reconstructed to the configuration, and to the lines and grades shown by the plans. Generally sidewalks, sidewalk ramps, driveways, and bicycle/pedestrian paths should be constructed after the curbing.

### **2302.4 Bicycle/Pedestrian Paths**

Asphalt bicycle/pedestrian paths shall be constructed in accordance with the provisions of Section 2201 and Section 2205 "Asphalt Paving" and in accordance with the applicable provisions of Paragraph 2302.3 The sidewalks, sidewalk ramps, driveways or bicycle/pedestrian paths shall be constructed or reconstructed to the configuration, and to the lines and grades shown by the plans. Generally sidewalks, sidewalk ramps, driveways, and bicycle/pedestrian paths should be constructed after the curbing.

### **2302.5 Method of Measurement**

- A. Sidewalks:** Sidewalks will be measured per square foot (square meter or tenth part thereof).
- B. Temporary Sidewalks:** Temporary sidewalks will be measured by one of the following:
  1. Per ton (metric ton) or tenth part thereof.
  2. Per square foot (square meter or tenth part thereof).
- C. Driveways:** Driveways will be measured by one of the following:
  1. Per ton (metric ton) or tenth part thereof.
  2. Per square foot (square meter or tenth part thereof).
- D. Bicycle Pedestrian Paths:** Bicycle/Pedestrian paths will be measured by one of the following:
  1. Per ton (metric ton) or tenth part thereof.

2. Per square foot (square meter or tenth part thereof).

**2302.6 Basis of Payment**

All items in this section will be paid for at the contract unit bid price.

**SECTION 2303 ROCK BLANKET**

**2303.1 Summary**

This section governs the construction of a protecting blanket of rock or broken concrete on slopes, channel bank or stream banks.

**2303.2 Materials**

The material for rock blanket shall be durable stone or broken concrete containing a combined total of not more than 10 percent of earth, sand, shale, and non-durable rock. When broken concrete is accepted, reinforcing shall be neatly chipped from all faces and shall not protrude from an in-place exposed face. The material shall contain a large percentage of pieces as large as the thickness of the blanket will permit, with enough smaller pieces of various sizes to fill the larger voids. Acceptance of quality and size of material may be made by visual inspection at the job site.

Rock Blanket shall be specified by class as shown in the following tables:

Percent Heavier Than										
Class	1 Ton	½ Ton	¼ Ton	250 lbs	200 lbs	180 lbs	75 lbs	60 lbs	10 lbs	5 lbs
1 ton	50+	95+								
½ ton	0	50+	95+							
¼ ton		0	50+				90+			
Facing					0		50+			90+
Light 24"			0		50+					90+
Light 18"				0		5-15		50-70	85-100	

Percent Heavier Than										
Class	1.75 MT	1 MT	½ MT	¼ MT	90 kg	80 kg	35 kg	25 kg	5 kg	2 kg
1 ton	50+	95+								
½ ton	0	50+	95+							
¼ ton		0	50+				90+			
Facing					0		50+			90+
Light 600			0		50+					90+
Light 450				0		5-15		50-70	85-100	

**2303.3 Construction Requirements**

A trench at the toe of the slope shall be excavated to the elevation as shown on the plans or to a minimum of 2 feet (600 mm) when not shown. The slopes shall conform to the proper cross section and be compacted to a uniform density as required for adjacent material. The rock or broken concrete shall be placed on the slope, to the prescribed thickness, elevation and extent, and shall be manipulated so that the flat sides are in contact, thereby eliminating large voids. The outside of the blanket shall present an appearance free from segregation and with a proportionate amount of the larger pieces showing.

**2303.4 Method of Measurement**

Rock blanket will be measured by one of the following:



- A. Per square yard (square meter) or tenth part thereof.
- B. Per ton (metric ton) or tenth part thereof.

### 2303.5 Basis of Payment

Rock blanket will be paid for by the contract unit bid price.

## SECTION 2304 CONCRETE PAVER STONES (For Median Treatment)

### 2304.1 Referenced Standards

The following standards are referenced directly in this section. The latest version of these standards shall be used.

#### American Society of Test Methods (ASTM)

- C33 – Standard Specification for Concrete Aggregates
- C67 – Standard Test Methods for Sampling and Testing Brick and Structural Clay Tile
- C140 – Standard Test Methods for Sampling and Testing Concrete Masonry Units and Related Units
- C150 – Standard Specification for Portland Cement
- C207 – Standard Specification for Hydrated Lime for Masonry Purposes
- C418 – Standard Test Method for Abrasion Resistance of Concrete by Sandblasting
- C595 – Standard Specification for Blended Hydraulic Cements
- C618 – Standard Specification for Coal Fly Ash and Raw or Calcined Natural Pozzolan for Use in concrete.
- C936 – Standard Specification for Solid Concrete Interlocking Paving Units

#### Midwest Concrete Industry Board (MCIB)

Mix No. WA610–1–4

### 2304.2 Summary

This section governs the furnishing of all labor, equipment and tools and for the performance of all work necessary to construct concrete paver stone paving.

### 2304.3 Materials

#### A. Interlocking Concrete Paver Stones (ASTM Designation C936):

1. **Paver stones** shall be cobblestone style consisting of full stones, 4 5/8" by 7" by 2 3/8" (117 mm by 178 mm by 60 mm); two thirds stones, 4 5/8" by 4 5/8" by 2 3/8" (117 mm by 117 mm by 60 mm); and one third stones, 4 5/8" by 2 5/16" by 2 3/8" (117 mm by 59 mm by 60 mm). The mix of stones sizes shall be approximately 28% full size, 57% two thirds size and 15% one third size.
2. **Cementitious Materials:** Materials shall conform to the following ASTM specifications as they apply
  - a. Portland Cements – Specification C150
  - b. Blended Cements – Specification C595
  - c. Hydrated Lime Type S – Specification C207
  - d. Pozzolans – Specification C618
3. **Aggregates:** Aggregates shall conform to ASTM Specifications C33 for Normal Weight Concrete Aggregate.

4. **Other Constituents:** Air-entraining agents, coloring pigments, integral water repellents, finely ground silica, etc. shall conform to ASTM standards where applicable, or shall be previously established as suitable for use in concrete.
5. **Physical Requirements**
  - a. **Compressive Strength:** At the time of delivery to the work site, the average compressive strength shall be not less than 8,000 psi (55.2 MPa) with no individual unit strength less than 7,200 psi (49.6 MPa), with testing procedures in accordance with ASTM Standard C140.
  - b. **Absorption:** The average absorption shall not be greater than 5% with no individual unit absorption greater than 7%.
  - c. **Durability:** The manufacturer shall certify either by proven field performance or the laboratory freeze-thaw test that the paving units have adequate durability.
  - d. **Proven Field Performance:** Satisfactory field performance is indicated when units similar in composition, and made with the same manufacturing processes those to be supplied to the purchaser, do not exhibit objectionable deterioration after at least three years. The units used as the basis for proven field performance shall have been exposed to the same environmental factors as is contemplated for the units supplied to the purchaser.
  - e. **Freeze-Thaw Test:** When tested in accordance with Section 8 of ASTM C67, Specimens shall have no breakage and not greater than 1.0% loss in dry weight of any individual unit when subjected to 50 freeze-thaw cycles. This test shall be conducted not more than 12 months prior to delivery of units.
  - f. **Abrasion Resistance:** When tested by sandblasting in accordance with ASTM C418, Specimens shall not have greater volume loss than 0.3 cubic inches per square inch (15 cubic cm per 50 square cm). The average thickness loss shall not exceed 1/8 inch (3 mm).
  - g. **Permissible Variations in Dimensions:** Length or width of units shall not differ by more than 1/16 inch (1.5 mm) from approved samples. Heights of units shall not differ by more than 1/8 inch (3 mm) from the specified standard.
  - h. **Visual Inspection:** All units shall be sound and free of defects that would interfere with the proper placing of unit or impair the strength or permanence of the construction. Minor cracks incidental to the usual methods of manufacturer, or minor chipping resulting from customary methods of handling in shipment and delivery, shall not be deemed grounds for rejection.
6. **Sampling and Testing:** The purchaser or his authorized representative shall be accorded proper facilities to inspect and sample the units at the place of manufacture from the lot ready for delivery. Sampling and testing of units shall be in accordance with ASTM Methods C140 except as required.
7. **Rejection:** In case the shipment fails to conform to the specified requirements, the manufacturer may sort it, and new test units shall be selected at random by the purchaser from the retained lot and tested at the expense of the manufacturer. In case the second set of test units fails to conform to specified requirements, the entire lot shall be rejected.
8. **Expense of Tests:** The expense of inspection and testing shall be borne by the purchaser unless otherwise agreed.
- B. **Base Course Concrete:** Base course concrete shall conform to the requirements of MCIB Mix No. WA610-1-4.
- C. **Sand for Laying Course:** The sand for the laying course shall be a well graded, clean, washed, sharp sand with 100% passing a 3/8" (9.5 mm) sieve size and a maximum of 3% passing a No. 200 (75 um) sieve size.

This is commonly known as manufactured concrete sand, limestone screening, or similar. Mason Sand will not be permitted.

#### **2304.4 Construction Details**

- A. Product Handling:** Paver stones shall be delivered and unloaded at jobsite on pallets and bound in such a manner that no damage occurs to the product during handling, hauling and unloading.
- B. Edge Restraint:** All edges of the installed paver stone shall be restrained by the concrete curb, concrete sidewalk, or another suitable method for preventing the movement of the edge stones.
- C. Concrete Base Course:** A concrete base course shall be constructed in accordance with the requirements of Section 2301. The base course shall be shaped to the grade and cross section as shown on the plans with an allowable tolerance of 1/4 inch (5 mm). The base course shall be 4 inches (100 mm) thick, and should be graded to allow a 1 inch (25 mm) thick sand course between the base and the paving stones. Pavement for concrete base course shall be subsidiary to the bid items.

The finished base course must be approved by the Engineer before the placement of the sand laying course. The uncompacted sand laying course shall be spread evenly over the area to be paved and then screened to a level that will produce 1 inch (25 mm) thickness when the paver stones have been placed and vibrated. Once screened and leveled to the desired elevation, the sand laying course shall not be disturbed in any way.

- D. Placing Paver Stones:** The paver stones shall be installed in rows perpendicular to the major axis of the median being paved. Within each row the stone sizes shall be randomly mixed so that joints between stones are not normally aligned with joints between stones in adjacent rows. No joints shall be aligned for more than three consecutive rows. The paver stones shall be laid in such a manner that the desired pattern is maintained and the joints between the stones are as tight as possible. For maximum interlock the joints between stones should not exceed 1/8 inch (3 mm). String lines should be used to hold all pattern lines true.

The gaps at the edge of the paver surface shall be filled with standard edge stones or with stones cut to fit. Curing shall be accomplished to leave a clean edge to the traffic surface using a double-headed breaker or a masonry saw. However, when cutting precision designed areas, a masonry saw should be used. Whenever possible, no cuts should result with a paver less than 1/3 of original dimension.

Paver stones shall be vibrated to their final level in the sand laying course by two or three passes of a vibrating compactor capable of 3,000 to 5,000 pounds (1360 kg to 2270 kg) compaction force with the surface clean and joints open. After vibration, clean concrete sand containing at least 30% of 1/8 inch (3 mm) particles shall be spread over the paver stone surface, allowed to dry, and vibrated into the joints with additional passes of the plate vibrator so as to completely fill the joints.

Surplus material shall then be swept from the surface. Upon completion of work covered in this Section, the Contractor shall clean up all work areas by removing all debris, surplus material and equipment from the site.

After final vibrating, the surface shall be true to grade and shall not vary by more than 1/4 inch (5 mm) when tested with a 10 feet (3.05 m) board at any location on the surface.

#### **2304.5 Method of Measurement**

Concrete Paver Stones will be measured by the square foot (square meter or tenth part thereof).

#### **2304.6 Basis of Payment**

Concrete Paver Stones will be paid for by the contract unit bid price.

## **SECTION 2305 MAINTENANCE OF TRAFFIC**

### **2305.1 Referenced Standards**

The following standards are referenced directly in this section. The latest version of these standards shall be used.

#### **American Traffic Safety Services Association (ATSSA)**

Quality Standards for Work Zone Traffic Control Devices

Manual of Uniform Traffic Control Devices, Part VI (MUTCD)

### **2305.2 Summary**

This section governs the furnishing of all labor, equipment and tools and for the performance of all work necessary to provide Maintenance of Traffic as specified herein, on the plans or within the Special Provisions.

### **2305.3 General**

The Contractor is required to maintain access to all properties served by the streets within the construction site limits.

### **2305.4 Traffic Maintenance and Warning Devices**

The Contractor will be responsible for arranging for installation of the necessary traffic control devices (with the exception of the barricades and other channelizing devices) a minimum of 48 hours prior to beginning the project so that inspection can be conducted by the Engineer.

Traffic maintenance devices including barricades, flashing lights, flag persons and other traffic control devices shall be in conformance with "Part VI of the Manual on Uniform Traffic Control Devices" latest edition.

### **2305.5 Flashers and Other Traffic Control Devices**

All traffic control devices shall be maintained in acceptable condition as defined by the latest ATSSA "Quality Standards for Work Zone Traffic Control Devices." Devices in unacceptable or marginal condition as determined above shall be removed from the job site and replaced with devices in acceptable condition.

### **2305.6 Method of Measurement**

Maintenance of Traffic will be measured per each device per day listed in the proposal and as adjusted by the Engineer during construction. The device must be set for at least one-half of a calendar day for it to be measured for payment.

### **2305.7 Basis of Payment**

Maintenance of Traffic will be paid for by one of the following:

- A. Contract unit bid price
- B. Contract lump sum bid price

## **SECTION 2306 PAVEMENT MARKINGS**

### **2306.1 Referenced Standards**

The following standards are referenced directly in this section. The latest version of these standards shall be used.

#### **American Society of Test Methods (ASTM)**

C321 – Standard Test Method for Bond Strength of Chemical-Resistant Mortars

C501 – Standard Test Method for Relative Resistance to Wear of Unglazed Ceramic Tile by the Taber Abraser

- D36 – Standard Test Method for Softening Point of Bitumen (Ring and Ball Apparatus)
- D92 – Standard Test Method for Flash and Fire Points by Cleveland Open Cup Tester
- D93 – Standard Test Methods for Flash Point by Pensky Martens Closed Tester
- D256 – Standard Test Method Methods for Determining the Izod Pendulum Impact Resistance of Plastics
- D476 – Standard Classification for Dry Pigmentary Titanium Dioxide Products
- D562 – Standard Test Method for Consistency of Paints Measuring Krebs Unit (KU) Viscosity Using a Stormer Type Viscometer
- D570 – Standard Test Method for Water Absorption of Plastics
- D638 – Standard Test Method for Tensile Properties of Plastics
- D711 – Standard Test Method for No–Pick–Up Time of Traffic Paint
- D768 – Standard Specification for Yellow Iron Oxide Hydrated
- D868 – Standard Test Method for Evaluating Degree of Bleeding of Traffic Paint
- D969 – Standard Test Method for Laboratory Determination of Degree of Bleeding of Traffic Paint
- D1152 – Standard Specification for Methanol (Methyl Alcohol)
- D1155 – Standard Test Method for Roundness of Glass Spheres
- D1199 – Standard Specification for Calcium Carbonate Pigments
- D1210 – Standard Test Method for Fineness of Dispersion of Pigment–Vehicle Systems by Hegman–Type Gage
- D1214 – Standard Test Method for Sieve Analysis of Glass Spheres
- D1475 – Standard test Method for Density of Liquid Coatings Inks and Related Products
- D2240 – Standard Test Method for Rubber Property–Durometer Hardness
- D2243 – Standard Test Method for Freeze–Thaw Resistance of Waterborne Coatings
- D2369 – Standard Test Method for Volatile Content of Coatings
- D2805 – Standard Test Method for Hiding Power of Paints by Reflectometry
- D3723 – Standard Test Method for Pigment Content of Water Emulsion by Low Temperature Ashing
- D3960 – Standard Practice for Determining Volatile Organic Content (VOC) of Paints and Related Coatings
- D4060 – Standard Test Method for Abrasion Resistance of Organic Coatings by the Taber Abraser
- D4061 – Standard Test Method for Retroreflectance of Horizontal Coatings
- D4366 – Withdrawn in 2003 and replaced by ANSI/ISO 1522
- D4796 – Standard Test Method for Bond Strength of Thermoplastic Traffic Marking Materials
- D5420 – Standard Test Method for Impact Resistance of Flat, Rigid Plastic Specimen by Means of a Striker Impacted by a Falling Weight (Gardner Impact)

- E70 – Standard Test Method for pH of Aqueous Solutions with the Glass Electrode
- E303 – Standard Test Method for Measuring Surface Frictional Properties Using the British Pendulum Tester
- E308 – Standard Practice for Computing the Colors of Objects by Using the CIE System
- E660 – Standard Practice for Accelerated Polishing of Aggregates or Pavement Surfaces Using a Small–Wheel, Circular Track Polishing Machine
- E1347- Standard Test Method for Color and Color–Difference Measurement by Tristimulus Colorimetry
- E1349 – Standard Test Method for Reflectance Factor and Color by Spectrophotometry Using Bidirectional (45:0 or 0:45) Geometry

**American Association of State Highway and Transportation Officials (AASHTO)**

- M 247 - Standard Specification for Glass Beads Used in Traffic Paint
- M 249 - Standard Specification for White and Yellow Reflective Thermoplastic Striping Material (Solid Form)
- T 250 - Standard Method of Test for Thermoplastic Traffic Line Material

**Manual of Uniform Traffic Control Devices**, latest edition (MUTCD)

**American Concrete Institute (ACI 301)**

- ACI 503 - Guide for the Selection and Use of Structural Adhesives with Concrete

**Federal Test Methods**

- Federal Test Method Standard No. 141, Method 4252 – Paint, Varnish, Lacquer and Related Materials; Methods of Inspection, Sampling and Testing
- Federal Test Method Standard No. 141a, Method 6121 – Paint, Varnish, Lacquer and Related Materials; Methods of Inspection, Sampling and Testing
- Federal Standard 595, Colors used in Government Procurement
- Federal Specification TT–P–115a – Paint, Traffic (Highway, White and Yellow)
- Federal Specification TT–P–1952B – Paint, Traffic and Airfield Marking, Water Emulsion Base  
“Standard Color Chips for Highway Signs” (US Bureau of Public Roads, Washington D.C.)

**2306.2 Summary**

This section governs the furnishing of labor, equipment, and materials and for the performance of work necessary to furnish and install white and yellow permanent or temporary retro–reflectorized pavement marking materials.

**2306.3 General**

The permanent pavement markings shall be installed immediately after the roadway surface is complete unless prior approval is received by the Engineer. The installation of the yellow markings (as required) is the first priority. If the permanent markings cannot be installed and thus the roadway would be unmarked overnight, temporary removable markings shall be installed and remain until the permanent markings can be installed. The contractor shall make every possible effort to remove the temporary pavement markings and install permanent pavement markings within 48 hours. Only under extreme circumstances and at the approval of the pavement marking inspector or the engineer, will the duration of the temporary pavement markings be extended. Under no circumstance should the temporary pavement markings be in place for more than 2 weeks. If permanent markings cannot be installed within

the specified time then semi-permanent markings shall be installed following the guide lines as set forth in the latest edition of the Manual on Uniform Traffic Control Devices (MUTCD) Part VI, Sections F6 and G6. The temporary removable markings shall be removed prior to installation of the permanent markings. In situations where markings conflict with the traffic routing, such as a lane closure or a lane diversion, conflicting markings shall be removed prior to application of the next set of markings.

#### 2306.4 Striping Applicability Chart

These charts provide guidance for the selection of striping materials.

Marking Material	Roadway Surface	Application	Durability
Thermoplastic	New asphalt	Permanent	High
Aggressive bond thermoplastic	Aged asphalt, concrete	Permanent	High
Preformed thermoplastic	Asphalt, concrete	Permanent	High
Cold plastic	Asphalt, concrete	Permanent	Moderate
Paint	All surfaces	Permanent, temporary	Low
Epoxy	All surfaces	Permanent	High
Temporary Tape (Type I)	All surfaces	Temporary	Low
Temporary Tape (Type II)	All surfaces	Temporary	Low
Line masking tape	All surfaces	Temporary	Low

Roadway Surface	Permanent Marking	Temporary Marking
New asphalt	Thermoplastic	Temporary Tape (I or II)
Old asphalt	Aggressive bond thermoplastic	Temporary Tape (I or II)
Slurry or microsurface	Thermoplastic	Temporary Tape (I or II)
Milled concrete or asphalt	Not applicable	Paint
Asphalt to be milled	Not applicable	Paint
Base asphalt	Not applicable	Paint, Temporary Tape (Type II)
New or old concrete	Aggressive bond thermo, Epoxy	Paint
Concrete	Inlaid cold plastic	Paint
Diamond ground concrete	Epoxy	Paint

Note: Old asphalt is asphalt which is more than 6 months old, or which has been open to traffic.

#### 2306.5 Symbol Applicability Charts

These charts provide guidance for the selection of text and non-text symbol materials.

Roadway Surface	Non-Text Symbols	Temporary Non-Text Symbols
New asphalt	Pre-formed thermoplastic, thermoplastic	Temporary Tape (I or II)
Old asphalt	Pre-formed thermoplastic, thermoplastic	Temporary Tape (I or II), paint
Slurry or microsurface	Thermoplastic	Temporary Tape (I or II), paint
Milled concrete or asphalt	Not applicable	Paint
Asphalt to be milled	Not applicable	Paint
Base asphalt	Not applicable	Paint
New or old concrete	Aggressive bond thermo, inlaid	Temporary Tape (I or II), paint



	cold plastic	
Concrete	Inlaid cold plastic	Temporary Tape (I or II), paint
Diamond ground concrete	Inlaid cold plastic	Temporary Tape (I or II), paint

Roadway Surface	Text Symbols	Temporary Text Symbols
New asphalt	Pre-formed thermoplastic	Temporary Tape (I or II)
Old asphalt	Pre-formed thermoplastic	Temporary Tape (I or II), paint
Slurry or microsurface	Pre-formed thermoplastic	Temporary Tape (I or II), paint
Milled concrete or asphalt	Not applicable	Paint
Asphalt to be milled	Not applicable	Paint
Base asphalt	Not applicable	Paint
New or old concrete	Inlaid cold plastic	Temporary Tape (I or II)
Concrete	Inlaid cold plastic	Temporary Tape (I or II)
Diamond ground concrete	Inlaid cold plastic	Temporary Tape (I or II)

**2306.6 Prequalification:**

- A. Manufacturers interested in prequalifying material under this specification shall submit to the Engineer:
  - 1. A sample of the material. Sample quantities are described in each section.
  - 2. Certifications by qualified testing laboratories that the material meets all required tests.
  - 3. A list of existing installations.
- B. The Engineer may test submitted samples or materials as used for compliance with all requirements of this specification.
- C. Products will remain on the prequalified list as long as the results of verification testing and field performance are satisfactory. Any changes in formulation should be reported to the Engineer for review and evaluation to determine if requalification is necessary
- D. No material shall be used unless the material has been prequalified or approved by the Engineer.
- E. A list of qualified materials by manufacturer may be maintained by the Owner.

**2306.7 Materials**

- A. **Pre-Mix Glass Spheres:** Pre-mix glass spheres shall be uncoated and conform to AASHTO M247 Type 1. The glass spheres used in the formulation shall be lustrous, free from film, scratches, and pits. The glass spheres shall also meet the following requirements:
  - 1. **Roundness:** The roundness of the spheres shall be a minimum of 70% when tested in accordance with ASTM D1155.
  - 2. **Gradation:** The gradation when tested in accordance with the method provided in ASTM D1214 (by use of U.S. Standard Sieves) shall be:

Size of Sieve	Mass % Passing
No. 18 (1.00 mm)	80-100
No. 50 (300 µm)	20-50
No. 80 (180 µm)	0-10



3. **Refractive Index:** When tested by a liquid immersion method at 77 degrees F (25degrees C), the refractive index of the spheres shall be a minimum of 1.50.

B. **Drop-On Glass Spheres:** The spheres shall be manufactured from glass of a composition designed to be highly resistant to traffic wear and to the effects of weathering. The particles shall be spherical in shape, containing not more than thirty percent (30%) of irregularly shaped particles. They shall be essentially free of sharp angular particles, and particles showing milkiness or surface scoring or scratching. They shall meet the requirements of AASHTO M247 Type 1.

1. **Gradation:** The gradation when tested in accordance with the method provided in ASTM D1214 (by use of U.S. Standard Sieves) shall be:

Size of Sieve	% Passing (by Weight)
No. 20 (850 μm)	100
No. 30 (600 μm)	80–100
No. 50 (300 μm)	18–35
No. 80 (180 μm)	0–10
No. 100 (150 μm)	0–2

2. **Refractive Index:** When tested by a liquid immersion method at 77 degrees F (25 degrees C), the refractive index of the spheres shall be within the range of 1.50 to 1.60.

3. **Moisture Proof Requirements:** The spheres shall show no tendency to absorb moisture in storage and shall remain free of clusters and hard lumps. The spheres shall flow freely from dispensing equipment at any time when surface and atmospheric conditions are satisfactory for application

C. **Thermoplastic Pavement Markings:** This specification covers a white and yellow thermoplastic reflectorized pavement marking material of a type that is applied to asphalt road surfaces in a molten state by mechanical means to receive a surface application of glass spheres, and which upon cooling to normal pavement temperature, produces an adherent reflectorized stripe of specified thickness and width and is capable of resisting deformation.

1. **Characteristics:** The material shall not exude fumes that are toxic, obnoxious or injurious to person or property, when it is heated to the temperature range specified by the manufacturer for application. It shall remain stable when held for 4 hours at this temperature, or when subject to 3 reheatings after cooling to ambient temperature.

The temperature–viscosity characteristics of the plastic material shall remain constant throughout repeated reheatings, and shall show like characteristics from batch to batch. There shall be no obvious change in color of the material either as a result of repeated reheatings or from batch to batch.

The thermoplastic material shall easily extrude from the equipment to produce a cross–section of line 90 to 125 mil (1.5 mm to 4.8 mm) thick, which shall be continuous and uniform in shape, and have clear and sharp dimensions.

2. **Serviceability:** The compound shall resist deterioration by contact with sodium chloride, calcium chloride or other chemicals used to prevent roadway ice, or because of the oil content of pavement materials or from oil droppings or other effects of traffic. The markings shall remain intact under normal traffic conditions at temperatures below 140 degrees F (60 degrees C).

3. **Specific Gravity:** The material's specific gravity shall not be less than 1.8 nor exceed 2.3 referred to water at 77 degrees F (25 degrees C) when determined by a water displacement method at 77 degrees F (25 degrees C).

4. **Set Time:** When applied at the specified temperature and thickness, the material shall set to bear traffic in not more than 2 minutes when the air temperature is 50 degrees F (10 degrees C) and not more than 10 minutes when the air temperature is 90 degrees F (32 degrees C).
5. **Composition:** The thermoplastic pavement marking material shall be homogeneously composed of pigment, filler, resin binder and glass reflectorizing spheres. The solid resin shall be a "maleic-modified glycerol ester resin" (alkyd binder) comprising at least one-third of the binder compositions and be no less than eight (8) percent by weight of the entire material formulation. The alkyd binder shall consist of a mixture of synthetic resins (at least one of which is solid at room temperature), and high boiling point plasticizers. The material shall not contain any petroleum derived ingredients. Yellow pigment shall be heat stabilized encapsulated lead chromate. The thermoplastic pavement marking material shall contain the following ingredients:

INGREDIENT (Percent by Weight)	WHITE	YELLOW
Binder (See Note A below)	18.0 min.	18.0 min.
Titanium Dioxide	10.0min.	—
Glass Spheres	20.0–50.0	20.0–50.0.
Lead Chromate	—	2.0 – 4.5
Inert Fillers	42.0 max	50.0 max

The material shall be thoroughly mixed and furnished in a free flowing granular form. The material shall meet the requirements of this specification for a period of one year. The material shall readily melt in a uniform mixture. The material shall be free from all skins, dirt, and foreign objects. It shall be of such composition that it will not bleed, stain or discolor when applied to bituminous pavement. The manufacturer shall replace material not meeting the above requirements.

6. **Color:** The color of the thermoplastic material after heating for 4 hours  $\pm$  5 minutes at 425  $\pm$  3 degrees F (218  $\pm$  1.4 degrees C) shall conform to the following when tested by Federal Test Method Standard 141 Method 4252:

White:	Federal Color Chip No. 37875 (Fed. Std. No. 595)
Yellow:	Federal Color Chip No. 13538 (Fed. Std. No. 595)

7. **Reflectance:** The daylight luminous reflectance of the white material shall be not less than 75% when tested according to ASTM E1347. The yellow shall have a minimum brightness of 45% relative to magnesium oxide, and shall be within the green and red tolerance of the "Standard Color Chips for Highway Signs (January 1939)" obtainable from the United States Bureau of Public Roads, Washington, D.C. (TT-P-115a).
8. **Softening Point:** After heating the thermoplastic material for 4 hours + 5 minutes at 425 + 3 degrees C (218 + 1.4 degrees C) and testing in accordance with ASTM D36, the material shall have a softening point 215 + 15 degrees F (102 + 7.1 degrees C).
9. **Flowability:** After heating the thermoplastic material for 4 hours + 5 minutes at 425 + 3 degrees F (218 + 1.4 degrees C) and testing for flowability, the white thermoplastic shall have a maximum percent residue of 18 percent and the yellow thermoplastic shall have a maximum residue of 21 percent.
10. After heating the thermoplastic material for 8.5 hours + 5 minutes at 425 + 3 degrees F (218 + 1.4 degrees C) and testing for flowability, the thermoplastic shall have a maximum percent residue of 28 percent.

11. **Indentation Resistance:** Hardness shall be measured by a Shore Durometer, Type A2, as described in ASTM D2240, except that the Durometer and the panel shall be at 77 degrees F (25 degrees C), and a 4.4 lb (2 kg) load applied. After 15 seconds, the reading shall be not less than 55.
12. **Abrasion Resistance:** The material shall not show a maximum loss of 0.02 ounces (0.5 g) subjected to 200 revolutions on a Taber Abraser at 77 degrees F (25 degrees C), using H-22 calibrate wheels, weighted to 17.6 ounces (500 g). The wearing surface should be kept wet with distilled water throughout the test. The panel for this test shall be prepared by forming a representative lot of material at a thickness of 125 mil (3 mm) on a 4 inch (100 mm) square panel (thickness 0.050 + 0.001 inch) [thickness 1.3 + 0.025 mm] on which a suitable primer has been previously applied.
13. **Low Temperature Impact Resistance:** The materials shall not fracture when subjected to an impact of 64 inch pounds at -4 degrees F (7.23 N-m at -20 degrees C) ( ), for at least 3 hours. The panel is then placed in an instrument also maintained at -4 degrees F (-20 degrees C), consisting of a 10.5 pound (4.7 kg) freely falling weight controlled to drop vertically for 6 inches (150 mm) onto the surface of the panel, which it strikes with a hemispherical indenter having a radius of .28 inches (7 mm).
14. **Water Absorption:** Materials shall have a maximum of 0.5 percent by weight of retained water when tested by ASTM D570, procedure (A).
15. **Yellowness Index:** The white thermoplastic material shall not exceed a yellowness index of 0.15.
16. **Flash Point:** The thermoplastic material shall have a flash point not less than 475 degrees F (246 degrees C) when tested in accordance with ASTM D92.
17. **Cracking Resistance:** After heating the thermoplastic material for 4 hours + 5 minutes at 425 + 3 degrees F (218 + 1.4 degrees C); applying to concrete blocks, and cooling 15 + 3 degrees F (7.1 + 1.4 degrees C), the material shall show no cracks. Properly applied, the material shall show less than six stress cracks per ten lineal feet (three lineal meters) of markings independent of pavement fracturing and faulting, for at least six months.

**D. Aggressive Bond Thermoplastic Pavement Markings:** This specification covers a white and yellow adhesive thermoplastic reflectorized pavement marking material that is applied to road surfaces, including Portland Cement Concrete (PCC) and aged asphalt without need of a primer/sealer. The material is applied to the road surface in a molten state by mechanical means with surface application of glass beads. Upon cooling to normal pavement temperature, it produces an adherent reflectorized stripe of specified thickness and width with limited thermal/seasonal deformation. In order to qualify as a non-sealer thermoplastic that can be applied to concrete surfaces without a sealer, the material must meet or exceed the requirements listed below.

1. **Characteristics:** The thermoplastic material shall be homogeneously composed of pigments, resins, polymers (adhesive constituent), glass reflectorizing spheres and other fillers  

The thermoplastic material shall be available in a variety of surface delineation colors from the same manufacturer. The manufacturer shall have the option of formulating the material according to their own specifications. However, certain physical and chemical requirements specified must be satisfied in order to qualify as a non-primed striping application for PCC and aged asphalt surfaces.

The material shall not exude fumes which are toxic, or injurious to persons or properties upon heating to application temperature.
2. **Specific Gravity:** The specific gravity of the white and yellow thermoplastic pavement marking material shall not exceed 2.15.
3. **Composition:** The pigment, intermix reflectorizing spheres, and fillers shall be uniformly dispersed in the resin and polymer upon heating to application temperature. The material shall be free of dirt and foreign matter and must meet or exceed the compositional requirements (percentage by weight)

indicated below. The total resin/binder content must be 22% min – 26% max (weight) of total product ingredients.

Test Component	White	Yellow (lead Chromate)	Yellow (Heavy Metal Free)
Glass Beads	30 % min	30 % min	30 % min
Pigment – TiO <sub>2</sub>	10 % min	N/A	N/A
Yellow (PbCrO <sub>3</sub> )	N/A	2 % min	N/A
Organic Yellow	N/A	N/A	Federal Color
Resin/Binder Content	22 % min	22 % min	22 % min
Inert Fillers	42.0 max	50.0 max	At manufacturer's discretion

4. **Color:** The thermoplastic material after heating for four hours  $\pm$  5 min. at  $425 \pm 3$  degrees F ( $218 \pm 2$  degrees C) and cooled to  $77 \pm 3$  degrees F ( $25 \pm 2$  degrees C) shall meet the following:

<b>White:</b>	Daylight reflectance at 45 degrees – 0 degrees – 80% min.
<b>Yellow:</b>	Daylight reflectance at 45 degrees – 0 degrees – 45% min.

Yellow color shall match Federal Test Standard Number 5958 – Color 13538 and lie within the following ranges:

X	0.485 – 0.510
Y	0.445 – 0.470

The chromaticities and luminance factors of ordinary colors of retroreflecting material shall be determined under an angle of illumination of 45 degrees; direction of view perpendicular to surface; and illumination CIE standard illuminant D65.

5. **Bond Strength:** After heating the thermoplastic material for four hours  $\pm$  5 minutes at  $425 \pm 3$  degrees F ( $218 \pm 2$  degrees C), the bond strength to Portland Cement Concrete (PCC) shall equal or exceed 275 psi (1.9 MPa) (ASTM Standard Test Method for Bond Strength of Thermoplastic Traffic Marking Materials – D4796 or ASTM C321). Failures of type described in Section 6.1 of ASTM D4796 bond test, must be repeated to obtain a quantifiable number. Failure of types 6.2, 6.3, and 6.4 of ASTM D4796 bond test, must exceed the specified thermoplastic – cement brick separation.
6. **Low Temperatures Cracking (Stress) Resistance for Extended Period:** The material shall be tested according to AASHTO T 250 Section 7 with Section 7.2.3. modified for an extended cold temperature of  $15 \pm 3$  degrees F ( $-9.4 \pm 2$  degrees C) exposure period of 72 hours. Any cracking shall constitute failure of the material to qualify as a non-sealer aggressive bonding material for PCC road surfaces.
7. **Impact Resistance (Gardner Falling Weight):** The test specimens should be formed according to the following procedure:

Heat approximately 14.1 ounces (400 grams) of material in an open pint can for 4 hours at  $425 \pm 3$  degrees F ( $218 \pm 2$  degrees C). Preheat specimen draw down blade, 2 inches x 4 inches (5 mm x 100 mm) with a 1/8 inch (3 mm) die opening for approximately one hour at  $425 \pm 3$  degrees F ( $218 \pm 2$  degrees C). The blade is usually placed in the oven containing the sample material during the last hour of sample heating.

After heating the sample for four hours, remove the sample and the draw down blade from the oven. Place the 125-mil blade onto a PCC block. Quickly pour the sample  $425 \pm 3$  degrees F ( $218 \pm 2$  degrees C) into the opening of the draw down screed and draw down the sample for the entire length of

the concrete block. Allow the drawn down test sample to condition in the open in the standard laboratory atmosphere,  $73.4 \pm 3$  degrees F ( $23 \pm 2$  degrees C) and  $50 \pm 5\%$  relative humidity.

Perform the testing procedure according to ASTM D5420 Section 11. Record and report the type of failure as (a) crack or cracks on the surface, (b) cracks that penetrate the entire thickness, (c) brittle shatter (the test specimen in several pieces after impact), or (d) ductile failure (the specimen is penetrated by a blunt tear).

Both the yellow and white non-sealer materials shall have minimum impact resistance of 80 inch pounds (9.0 N-m) with no visible surface cracks.

8. **Impact Resistance (Notched Izod):** After heating the material for four hours  $\pm$  5 minutes at  $425 \pm 3$  degrees F ( $218 \pm 2$  degrees C) and forming test specimens according to AASHTO T 250 Section 8, both the yellow and white samples shall be a minimum notched impact resistance of  $11.0 \pm 0.3$  inch pounds ( $1.24 \pm 0.03$  N-m). The specimens shall be tested both at room temperature  $73.4 \pm 3$  degrees F ( $23 \pm 2$  degrees C) and low temperature of  $15 \pm 3$  degrees F ( $9.4 \pm 2$  degrees C) in accordance with ASTM D256 test method A.
  9. **Oil and Grease Resistance:** The thermoplastic material shall show no signs of deterioration or solubility after motor oil is rubbed vigorously into a sample for 2 minutes and allowed to penetrate for 5 minutes.
  10. **Set Time:** When applied at a temperature range of  $412.5 \pm 12.5$  degrees F ( $211 \pm 7$  degrees C) and thickness of 90 to 125 mil (2.3 mm to 3 mm) the material shall set to bear traffic in not more than 2 minutes when the air temperature is  $50 \pm 3$  degrees F ( $10 \pm 2$  degrees C) and not more than ten minutes when the air temperature is  $90 \pm 3$  degrees F ( $32 \pm 2$  degrees C).
  11. **Flash Point:** The thermoplastic material shall have a flash point of not less than 500 degrees F (260 degrees C) when tested in accordance with ASTM D92.
  12. **Storage Life:** The material shall maintain the requirements of this specification for a minimum period of one year. The thermoplastic material must melt uniformly with no evidence of skins or unmelted particles for this one year time period. Any material failing to do so shall be replaced by the manufacturer at their expense.
  13. **Packaging and Marking:** The thermoplastic material shall be packaged in suitable containers to which it will not adhere during shipment and storage. The container of thermoplastic material shall weigh approximately 50 lb. (23kg). Each container shall designate user information, manufacturer's name and address, batch number and date of manufacture. Each batch manufactured shall have its own separate number. The label shall carry appropriate user warnings and instructions.
  14. **NTPEP Test Program:** The material must have been applied, without surface primer, on two NTPEP Decks (PCC) and evaluated for a period of at least one year. A minimum of 90% of the original pavement striping must be intact on the PCC decks after a one-year review period. The percent retention is calculated based on the measured test area square footage (square meter) (neglecting mil thickness wear down) minus the road surface areas that are exposed due to cracking and chipping away of thermoplastic from the concrete surface caused by product bond failure to the substrate.
- E. **Preformed Thermoplastic Pavement Markings:** This specification is for the furnishing of retroreflective preformed thermoplastic pavement marking materials that can be adhered to asphalt, concrete and Portland cement concrete pavements by means of heat fusion. The applied markings shall be very durable, oil and grease impervious and provide immediate and continuing retroreflectivity.
1. **Characteristics:** The preformed marking material shall consist of a resilient white and yellow polymer thermoplastic with uniformly distributed glass beads throughout its entire cross section.

Preformed words and symbols shall conform to the applicable shapes and sizes as prescribed in the latest revision of the Manual on Uniform Traffic Control Devices.

The preformed markings shall be fusible to asphalt concrete and Portland cement concrete pavements by means of the normal heat of a propane type of torch. Adhesives, primers or sealers shall not be used prior to the preformed marking application on asphalt concrete and Portland cement concrete pavements.

The preformed markings shall conform to pavement contours, breaks and faults through the action of traffic at normal pavement temperatures. The markings shall have resealing characteristics and be capable of fusing to itself and previously applied worn hydrocarbon and/or alkyd thermoplastic pavement markings.

The preformed markings shall be capable of application on new, dense and open graded asphalt concrete wearing courses during the paving operation in accordance with the manufacturer's instructions. After application, the markings shall be immediately ready for traffic. The preformed markings shall be suitable for use for one year after the date of receipt when stored in accordance with the manufacturer's recommendations.

The preformed thermoplastic markings shall not be brittle and must be sufficiently cohesive and flexible at temperatures exceeding 50 degrees F (10 degrees C) for one person to carry without the danger of fracturing the material prior to application.

2. **Composition:** The retroreflective pliant polymer thermoplastic pavement markings shall consist of a homogeneous mixture of high quality polymeric thermoplastic binders, pigments, fillers and glass beads. The thermoplastic material must conform to AASHTO designation M 249 with the exception of the relevant differences due to the material being supplied in a preformed state.
3. **Glass Beads:** The markings shall contain 30% glass spheres which shall conform to AASHTO M 247 Type 1, except that glass spheres shall have a minimum of 70% true spheres on each sieve and 80% true spheres overall.

The glass beads must be homogeneously blended throughout the material with a securely bonded protruding exposed layer of beads that provide immediate and continuous retroreflectivity; no additional glass beads shall be dropped on the material during application. Curved arrows must be available without protruding glass beads if reversibility is needed.

4. **Retroreflectivity:** The preformed marking shall upon application exhibit uniform adequate nighttime retroreflectivity. At 86 degree 30 feet (9.1 m) incidence angle and 1 degree 30 feet (9.1 m) divergence angle, the markings shall have average minimum intensities of 350 millicandelas for white and 175 millicandelas for yellow as measured with a MiroLux retroreflectometer.

Using a Taber Abraser with an H-18 wheel and a 4.4 ounce (125 g) load, the sample shall be inspected at 200 cycles, under a microscope, to observe the extent and type of bead failure. No more than 15% of the beads shall be lost due to pop-out and the predominant mode of failure shall be "wear down" of the beads.

5. **Color Characteristics:** The thermoplastic material without glass beads shall meet the following:

White:	Daylight reflectance at 45-degree/ 0 degree of 80% minimum
Yellow:	Daylight reflectance at 45-degree/ 0 degree of 45% minimum.

The daylight reflectance shall not change significantly when the preformed thermoplastic is properly applied to the roadway surface

For highway use, the white markings shall contain a minimum of 8% by weight of Titanium Dioxide pigment to ensure a color similar to Federal Highway White, Color No. 17886 Standard 595. Yellow



color shall reasonably match color chip Number 13538 of Federal Standard number 595 and be lead free.

6. **Skid Resistance:** The surface of the preformed thermoplastic markings shall provide a minimum skid resistance value of 45 BPN when tested according to ASTM E303.
  7. **Thickness:** The width of the supplied material shall have a minimum average thickness of 90 mils (2.3 mm).
  8. **Flexibility:** The preformed thermoplastic marking material shall have flexibility at 50 degrees F (10 degrees C) such that no cracking occurs in the test sample when a 1 inch by 6 inches (25 mm by 150 mm) sample is bent through an arc of 90 degrees at a uniform rate in 10 seconds (9 seconds per degree) over a one inch (25 mm) mandrel. The sample must be conditioned prior to testing at 50 + 2 degrees F (10 + 0.9 degrees C) for a minimum of four hours. At least two specimens tested must meet the flexibility requirements at 50 degrees F (10 degrees C) for a passing result.
  9. **Environmental Resistance:** The applied markings shall be resistant to deterioration due to exposure to sunlight, water, oil, diesel fuels, gasoline, pavement oil content, salt and adverse weather conditions.
  10. **Effective Performance Life:** When properly applied, in accordance with the manufacturer's instructions, the pavement markings shall be neat and durable. The markings shall remain retroreflective and show no fading, lifting, shrinkage, tearing, roll back or other signs of poor adhesion.
- F. **Cold Plastic Pavement Markings:** This specification covers a white and yellow pre-formed cold plastic reflectorized pavement marking material of a type that is applied to a road surface by an inlaid, pre-coated pressure sensitive adhesive that produces an adherent reflectorized stripe of specified thickness and width and is capable of resisting deformation.

1. **Characteristics:** The material shall be manufactured without the use of lead-chromate pigments or other, similar, lead-containing chemicals.

Glass beads shall be incorporated to provide immediate and continuing retroreflection. Ceramic skid particles shall be bonded to the top layer to provide a skid-resistant surface.

Preformed word and symbol markings shall conform to the applicable shapes and sizes as outlined in the Manual on Uniform Traffic Control Devices.

The preformed markings shall be capable of being adhered to pavements by an inlaid, pre-coated pressure sensitive adhesive. A surface preparation adhesive may be used to precondition the inlay pavement surface.

The preformed marking film shall mold itself to pavement contours by the action of traffic. Following proper inlay application and tamping, the markings shall be immediately ready for traffic.

2. **Composition:** The retroreflective pavement marking film shall consist of a mixture of high-quality polymeric materials, pigments and glass beads distributed throughout its base cross-sectional area. A reflective layer of glass beads and a layer of skid-resistant ceramic particles shall be bonded to the top urethane wearing surface. The urethane wear surface shall have a nominal thickness of 0.005 inches (13 mm). The film shall have a pre-coated, shear-resistant, pressure sensitive adhesive.
3. **Color:** The daytime color of the white film shall provide a minimum initial luminance factor, Y, of 80 and shall conform to the following chromaticity requirements:

WHITE		YELLOW	
X Values	Y Values	X Values	Y Values
0.290	0.315	0.474	0.455
.0310	0.295	0.491	0.435

WHITE		YELLOW	
0.330	0.360	0.512	0.486
0.350	0.340	0.536	0.463

The daytime color of the yellow film shall provide an initial luminance factor, Y, in a range of 36 to 59 and shall conform to the above chromaticity requirements:

Measurements shall be made in accordance with ASTM E1349, using illuminant "C" and 0/45 (45/0) geometry. Calculations shall be in accordance with ASTM E308 for the 2-degree observer.

4. **Reflectance:** The white and yellow films shall have the following initial minimum reflectance values as measured in accordance with the testing procedures of ASTM D4061. The photometric quantity to be measured shall be coefficient of retroreflected luminance ( $R_L$ ) and shall be expressed as millicandelas per square foot per foot-candle ( $\text{mcd}\cdot\text{ft}^{-2}\cdot\text{fc}^{-1}$ ) (millicandelas per square meter per lux ( $\text{mcd}\cdot\text{m}^{-2}\cdot\text{lux}^{-1}$ )).

	WHITE			YELLOW		
Entrance Angle	86.0°	86.0°	86.5°	86.0°	86.0°	86.5°
Observation Angle	0.2°	0.5°	1.0°	0.2°	0.5°	1.0°
Retroreflected Luminance $R_L$ ( $\text{mcd}\cdot\text{ft}^{-2}\cdot\text{fc}^{-1}$ )	700	500	400	410	250	175

5. **Skid Resistance:** The surface of the retroreflective films shall provide an initial minimum skid resistance value of 55 BPN as measured by the British Portable Skid Tester in accordance with ASTM E303.

The surface of the retroreflective film shall retain an average skid resistance value of 45 BPN, when tested in accordance with ASTM E303, for a period of one year when installed in non-snow removal areas. The 45 BPN minimum value shall be an average of several readings taken in both the wheel track and non-wheel track areas.

6. **Tensile Strength and Elongation:** The film shall have a minimum tensile strength of 150 lbs. per square inch (7.18 kilopascals) of cross-section when measured in the direction of the length of the roll and tested in accordance to ASTM D638, except that a sample 6 inch x 1 inch (150 mm x 25 mm) shall be tested at a temperature between 70 degrees F and 80 degrees F (21.1 degrees and 26.7 degrees C) using a jaw speed of 10 to 12 inches per minute. The sample shall have a maximum elongation of 50% at break when tested by this method.
7. **Reflectivity Retention:** The glass beads must be strongly bonded and not be easily removed by traffic wear. Using a Taber Abraser with an H-18 wheel and a 4.4 ounce (125 g) load, the sample shall be inspected at 200 cycles, under a microscope, to observe the extent and type of bead failure. No more than 15% of the beads shall be lost due to pop-out and the predominant mode of failure shall be "wear down" of the beads.
8. **Glass Beads:** The size, quality and refractive index of the glass beads shall be such that the performance requirements for the markings shall be met. The bead adhesion shall be such that beads are not easily removed when the material surface is scratched.

The film shall have glass bead retention qualities such that when a 2 inches by 6 inches (50 mm by 150 mm) sample is bent over a 1/2 inch (12.7 mm) diameter mandrel, with the 2 inch (50 mm) dimension perpendicular to the mandrel axis, microscopic examination of the area on the mandrel shall show no more than 10% of the beads with entrapment by the binder of less than 40%.

9. **Thickness:** The film, without adhesive, shall have a minimum thickness of 60 mil (1.55 mm).



**G. Lead-Free, Water-Borne Emulsion Based White and Yellow Traffic Paint:** The pavement marking paint shall be a rapid dry. The traffic paint shall provide optimum adhesion for glass spheres when both binder and glass spheres are applied in the recommended quantities.

- 1. Drying Time:** When applied at a wet film thickness of 15 mils (38mm) with a top dressing of 6–10 pounds (0.70 – 1.20 kg) of glass spheres per gallon (per liter) of paint and when the pavement temperature is between 50 degrees F and 120 degrees F (4.4 degrees C and 48.9 degrees C) and the relative humidity doesn't exceed 80%, the binder shall dry to a no-tracking condition in a minimum of 20 seconds and a maximum of 60 seconds.

These dry times shall not be exceeded when the paint is applied with specialized equipment so as to have the pigmented binder at a temperature of 150 degrees F to 170 degrees F (65.5 degrees C to 76.7 degrees C) at the spray gun.

The no-tracking condition shall be determined by passing over the applied line in a simulated passing maneuver with a passenger car traveling 35 MPH (56 KPH). There shall be no visual deposition of the paint to the pavement surface when viewed from a distance of 50 feet (15.2 meters). Furthermore, the pigmented binder, without glass spheres, shall dry to no-tracking condition in 180 seconds or less when tested in accordance with ASTM D711.

- 2. Directional Reflectance:** The daylight directional reflectance of white pigmented binder (without glass spheres) shall be not less than 85% relative to magnesium oxide when tested in accordance with Federal Test Method Standard No. 141a, Method 6121. If yellow, after drying shall suitably match color 33538 of Federal Standard 595.

The paint for the pavement markings shall contain no lead and/or chromium and shall have volatile organic content conforming to the latest Environmental Protection Agency regulations.

In addition, the paint and/or components shall conform to the American Society for Testing Materials (ASTM) as follows:

- D93 – Standard Test Methods for Flash Point by Pensky Martens Closed Tester
- D476 – Standard Specification for Titanium Dioxide Pigments, Type II Rutile
- D562 – Standard Test Method for Consistency of Paints Using Stormer Viscosimeter
- D711 – Standard Test Method for No-Pick-Up Time of Traffic Paint
- D768 – Standard Specification for Yellow Iron Oxide
- D868 – Standard Test Method for Evaluating Degree of Bleeding of Traffic Paint
- D969 – Standard Test Method for Laboratory Test for Degree of Bleeding of Traffic Paint
- D1152 – Standard Specification for Methanol (Methyl Alcohol)
- D1199 – Standard Specification for Calcium Carbonate Pigments
- D1210 – Standard Test Method for Fineness of Dispersion of Pigment-Vehicle Systems by Hegman-Type Gage
- D1475 – Standard test Method for Density of Paint, Varnish, Lacquer, and Related Products
- D2243 – Standard Test Method for Freeze-Thaw Resistance of Waterborne Coatings
- D2369 – Standard Test Method for Volatile Content of Coatings
- D2805 – Standard Test Method for Hiding Power of Paints by Reflectometry

- D3723 – Standard Test Method for Pigment Content of Water Emulsion by Low Temperature Ashing
- D3960 – Standard Practice for Determining Volatile Organic Content (VOC) of Paints and Related Coatings
- D4060 – Standard Test Method for Abrasion Resistance of Organic Coatings by Taber Abraser
- D4366 – Standard Test Methods for Hardness of Organic Coatings by Pendulum Damping Tests
- E70 – Standard Test Method for pH of Aqueous Solutions with the Glass Electrode
- E1347 – Standard Test Method for Color and Color-Difference Measurement by Tristimulus (Filter) Colorimetry

The paint shall show no cracking, flaking, blistering, appreciable loss of adhesion, softening, coagulation, discoloration, and have a minimum bleeding ratio of 0.97 when tested in accordance with Federal Specification TT-P-1952B.

The paint shall be capable of dilution with water at all levels without curdling or precipitation such that the wet paint can be readily cleaned up with water only.

The minimum contrast ratio shall be 0.96 when drawing down with a 0.005 mil film applicator on a 2A Leneta Chart or equal and air-dried for 24 hours. Contrast Ratio = Black/White.

- H. Temporary Tape:** This specification covers pavement marking tape of two colors, white and yellow, and of two types, Type I and Type II.

Type I-Regular (This type is not required to be easily removable intact.)

Type II-Removable (This type is to be readily removable intact, either manually or with a roll-up device after having been in place through the construction season.)

1. **General:** This material shall be a pavement striping tape designed to provide reflective delineation under both dry and moderate rainfall conditions. The tape shall consist of glass spheres tightly embedded to a binder; on a conformable backing pre-coated with a pressure sensitive adhesive. The striping material shall be thin, flexible, formable and following application shall remain conformed to the texture of the pavement surface. The tape shall be furnished in the color and type designated on the Plans or in the contract. The markings shall be pre-coated with a pressure sensitive adhesive and shall be capable of being adhered to asphalt concrete or Portland cement concrete in accordance with manufacturer's instructions without the use of heat, solvents or other additional adhesive means, and shall be immediately ready for traffic after application. The adhesive shall not require a liner or release paper. The striping material shall have a uniform appearance, free from cracks and the edges shall be true, straight and unbroken. The material shall be weather resistant and show no appreciable fading, lifting or shrinkage when applied in accordance with the manufacturer's recommendations.
2. **Color and Daylight Reflectance:** The daylight reflectance (ASTM E1347) of white shall be not less than 70%. The color of yellow shall be within the red and green tolerance limits of the Highway Yellow Color Tolerance Chart issued by the U.S. Department of Transportation.
3. **Dimensions:** The width and length shall be as shown on the Plans or in the contract. The material shall be available in rolls and there shall be no more than three splices per 50 yards (45.7 m) of length.
4. **Packaging:** The material shall be packaged in accordance with accepted commercial standards and when stored under normal conditions, shall be suitable for use for a period of at least one year after purchase.

5. **Adhesion:** The material shall adhere to asphalt and concrete surfaces when applied according to manufacturer's recommendations at surface temperatures above 50 degrees F (10 degrees C) and shall be immediately ready for traffic following application.
6. **Removability:** Type II tape shall be removable from asphalt and Portland cement concrete intact or in large pieces, either manually or with a roll-up device, at temperatures above 40 degrees F (4.5 degrees C) without use of heat, solvents, grinding or blasting.
7. **Reflection:** The white and yellow material shall be retroreflective, reflecting white or yellow respectively and shall be readily visible at night when viewed with automobile headlamps using high beams from a distance of at least 300 feet (91.4 m).
8. **Durability:** Type II material shall maintain adhesion, show no alligatoring, show no signs of pulling apart, and shall suffer no more than a 25% loss of beads, sand and grit when subjected to 30, 000 revolutions on a small-wheel circular track as described in ASTM E660, with the following variations or exceptions:
  - a. Two opposite wheels mounted with Goodyear 3.40-5 NHS Industrial Rib tires shall be used with a total load of 51.5 pounds (23.4 kg) on each tire. Tire air pressure shall be maintained at 25 pounds (11.3 kg). The wheels shall be mounted perpendicular to the specimens and toed out 2° to produce a slight abrading action.
  - b. Specimens shall be applied to 6 inch (150 mm) diameter dense graded bituminous concrete surface which has been compacted at 3000 psi (20.7 MPa) for two minutes. After application, the specimens shall be allowed to cure at least 16 hours before beginning the test.
9. **Prequalification:** Manufacturers interested in prequalifying material under this specification shall submit 20 linear feet (6 linear meters) of each color to the Engineer, and shall comply with the provisions of Paragraph 2307.4.
- I. **Epoxy:** This specification is for the application of epoxy resin and glass beads as reflective pavement markings on Portland cement concrete or bituminous pavements. The epoxy resin material shall be toxic heavy metal free, two-component, 100% solids, and shall be formulated and tested to perform as a pavement marking material with glass spheres applied to the surface. The two components are an epoxy resin and an amine curing agent. The contractor shall provide complete manufacturer's specifications and material safety data sheets to the Engineer for all material furnished.
  1. **Characteristics:** The material shall not exude toxic fumes when heated to application temperature. The material which, when mixed in the proper ratio and applied at 0.14 mil (500 μm) wet film thickness at 74.8 degrees F (23.8 degrees C) with the proper saturation of glass beads, has a no-tracking time of less than 40 minutes for slow curing material and less than 10 minutes for rapid curing material. The material shall be capable of fully curing under a constant surface temperature of 32 degrees F (0 degrees C) or above.
  2. **Properties of Cured Material**
    - a. **Color:** Provide white which complies with Federal Standard 595 17875. Provide yellow which matches the standard shade within the red and green tolerance limits when compared with the Highway Yellow Color Tolerance chart available from the U.S. Department of Transportation, Washington, D.C. (Federal Standard 595 13538).
    - b. **Abrasion Resistance:** 0.0028 ounces (80 mg) maximum loss when tested at 30 + 1.5 mils (750 + 38 μm) and a 72 hour cure and with a CS-17 wheel under a load of 2.2 lbs. (1000 grams) for 1000 cycles
    - c. **Hardness:** Shore D hardness of 75 minimum.

- d. **Adhesion to Concrete:** When catalyzed, has such a high degree of adhesion to the specified concrete surface that there is a 100% concrete failure. Apply the material at a film thickness of 15 + 1.5 mils (375µm + 38µm) to concrete with a minimum compressive strength of 4061 psi (28 MPa). Allow the material to cure for 72 hours at 77 degrees F (25 degrees C) before the test is performed.
- e. **Yellowness Index:** White only. Value after 72 hours in QUV – 30 maximum when tested at 15 ± 1.0 mils (375µm + 25µm) and a 72 hour cure.
- f. **Field Evaluation:** Field test materials at AASHTO NTPEP regional test facilities, which include both hot and cold weather conditions and are a minimum of six months in duration.

**3. Glass Beads for Drop-On Application (double drop system)**

- a. For the first drop, furnish large beads, which are compatible with the epoxy system, and comply with AASHTO M 247 except with the following gradation (FP-96, Type 4):

Sieve Size	Percent Passing
No. 10 (2.00 mm)	100
No. 12 (1.70 mm)	95 – 100
No. 14 (1.40 mm)	80 – 95
No. 16 (1.18 mm)	10 – 40
No. 18 (1.00 mm)	0 – 5
No. 20 (850 µm)	0 – 2

- b. For the second drop, furnish regular beads which are specifically manufactured to be compatible with the epoxy system, and which comply with the requirements of AASHTO M247, Type 1.
- c. Both types of beads are to be coated with a moisture resistant coating and an adhesion promoting coating which is compatible with the epoxy system.

**4. Test Methods**

- a. Adhesion to Concrete ACI 503, Appendix A.1
- b. Hardness ASTM D2240
- c. Abrasion Resistance ASTM C501

**5. Prequalification**

- a. Manufacturers interested in prequalifying material under this specification must comply with the provisions of Paragraph 2307.4 and shall provide a one liter sample of each color plus one liter of hardener to the Engineer for laboratory testing. Also include a copy of the quality control test report for each lot of material, an infrared spectroscopy analysis for each component if available, material safety data sheets and a complete set of installation recommendations and instructions. Forward an official copy of the AASHTO NTPEP test report along with evidence that the product in reference is identical to that submitted for prequalification.
- b. The material will be evaluated for compliance with all requirements of this specification, and the manufacturer will be notified of the results. Both component A and component B will be analyzed and "fingerprinted" using infrared spectroscopy for use in screening future verification samples to ensure that materials submitted for use are of an identical formulation as originally approved.
- c. Verification testing: The Engineer will take a one liter verification sample of Part A and Part B of the

epoxy from one lot of each color per project. Send the samples to the engineer for testing and evaluation. Lots previously tested will be exempted from testing and may be exempted from sampling if coordinated with the engineer. Samples may be tested using infrared spectroscopy and testing as necessary. Deviations as determined by comparison with the prequalification sample will be cause for removal from the prequalified list. The Engineer may also take a 0.5 gallon (2 liter) sample of each type of glass bead used on the project. Forward all samples to the engineer for verification testing

### **2306.8 Method of Installation**

The proposed permanent markings shall be laid out by the contractor in advance of the marking installation. Markings shall not be applied until the layout and conditions of the surface have been approved by the Engineer. If a paint line is used for layout purposes (in lieu of a chalk line or string line) the paint line shall not be wider than 1/2 inch (16.5 mm) in width. If wider, the paint shall be removed following the application of the final permanent marking. New markings shall match existing markings as applicable in areas abutting existing road surfaces. The surface shall be dry and all dust, debris, oil, grease, dirt, temporary markings and other foreign matter shall be removed from the road surface prior to the application of the permanent marking material.

The Contractor shall be responsible for keeping traffic off freshly applied markings until they have set sufficiently to bear traffic. Traffic control is the responsibility of the Contractor and shall conform to the MUTCD. Failure to comply with traffic control guidelines will result in the Pavement Marking Contractor being directed to stop operations and leave the site until proper and approved traffic control has arrived and put in place on site.

Temporary pavement markings shall be installed the same day that the existing pavement markings are damaged, removed or covered up prior to lane opening.

Temporary pavement markings shall be installed using the same cycle length as the permanent markings and be at least 2 feet (600 mm) long. Double yellow markings shall be used for temporary centerline and single white markings shall be used for temporary lane lines on four lane roadways. Single yellow markings shall be used for temporary centerline on two lane roadways as directed by the engineer.

Half-cycle lengths with a minimum of 2 foot (600 mm) stripe and 10 foot (3.05 m) gap should be used on roadways with severe curvature.

- A. Glass Spheres:** The drop on glass beads shall be applied at a rate of eight to ten pounds per 100 square feet (3.6 to 4.5 kg per 9.3 square meters).
- B. Thermoplastic Pavement Markings:** Thermoplastic material shall readily apply to the pavement at temperatures of 400 – 425 degrees F (204 – 218 degrees C) from approved equipment to produce an extruded line that shall be continuous and uniform in shape having clear and sharp dimensions. Application temperatures shall not exceed 450 degrees F (232 degrees C).

Thermoplastic may be used for cross walks and stop bars as specified under the conditions described herein. The thermoplastic markings shall be applied to the pavement surface in a molten state by mechanical means with surface application of glass spheres, and upon cooling to normal pavement temperature, produce an adherent retro-reflectORIZED stripe of specified thickness and width and capable of resisting deformation.

- 1. Equipment:** The equipment used to install the thermoplastic shall be as follows:
  - a.** A self-propelled machine is required in order to fulfill the timing needs of the marking installation for longitudinal lines.
  - b.** If thermoplastic is used for transverse lines, i.e., crosswalks and stop lines, a push cart shall be used according to the following requirements: Only one pass with the thermoplastic pavement marking equipment shall be allowed in order to provide the required line width according to the plans. Multiple passes of narrower lines with overlaps to provide the required width shall not be

allowed unless otherwise approved by the inspector after review of a test strip installation. If approved, the contractor shall be required to heat the seam with a torch and feather the overlapped material with a putty knife. Liquid thermoplastic shall not be used for word or symbol markings.

- c. Constructed to provide mixing and agitation of the materials. Conveying parts between the main material reservoir and the shaping die shall be constructed as to prevent accumulation and clogging.
- d. Constructed so that mixing and conveying parts up to and including the shaping die will maintain the materials at a temperature not less than 400 – 450 degrees F (204 – 232 degrees C). To assure that the material does not fall below the minimum temperature, the shaping die shall be heated by means of a gas-fired infrared heater or a heated, oil-jacketed system.
- e. Constructed as to insure continuous uniformity in the dimensions of the stripe. The applicator shall provide a means for cleanly cutting off square stripe ends and shall provide a method of applying “skip” lines. The equipment shall be constructed to be able to provide for varying die widths and to produce varying widths of traffic markings. The use of pans, aprons, or similar appliances with die overruns will not be permitted.
- f. All conditions apply as stated above for material temperatures, line definition and workmanship when a hand pushcart is used for cross walks. The Inspector will verify measurement.
- g. Equipped with a special kettle for melting and heating the material shall be provided. The kettle shall be equipped with a thermostat so that heating can be done by controlled heat transfer liquid rather than by direct flame so as to provide positive temperature control and prevent overheating of the material.
- h. Constructed for a nominal application of 90 – 125 mil (2.3 – 3.2 mm) thickness.
- i. The heater and applicator shall be so equipped and arranged as to meet the requirements of the National Board of Fire Underwriters of the National Fire Protection Association, of the state, and of the local authorities.
- j. Equipped with an automatic glass bead dispenser attached to the striping machine in such a manner that the beads are dispensed almost instantaneously upon the installed line. The glass bead dispenser shall be equipped with an automatic cut-off control synchronized with the cut-off of the thermoplastic material.
- k. The equipment shall be arranged as to permit preheating of the pavement immediately prior to application of the thermoplastic material, if preheating is recommended by the thermoplastic manufacturer.
- l. The applicator shall be capable of containing a minimum of 1000 pounds (453.6 kg) of molten material (not applicable for hand-liner use).
- m. The applicator shall be mobile and maneuverable to the extent that straight lines can be followed and normal curves can be made in a true arc.
- n. The Contractor’s striper shall be equipped with electrical foot (meter) counters. The counters shall individually tabulate the length of line applied by each gun whether solid or dashed. The Contractor shall determine the accuracy of the foot (meter) counters and establish an adjustment factor as required to determine the pay item quantities. The foot (meter) counters shall be periodically checked to assure accurate measurements. No thermoplastic shall be applied without the accurate operation of the foot (meter) counters. The Contractor shall provide the Engineer with a certified document on these calibrations.



## 2. Application over Existing Markings

- a. Existing thermoplastic markings on asphalt road surfaces may be over laid with thermoplastic material providing that the existing markings (thermoplastic) are less than 30 mils (760  $\mu\text{m}$ ) thick, and are securely bonded to the substrate. If the thermoplastic is greater than 30 mils (760  $\mu\text{m}$ ), or not securely bonded to the substrate, then it shall be ground to 30 mils (760  $\mu\text{m}$ ), or removed completely if not securely bonded to the road.
- b. Existing solvent based paint on asphalt road surfaces may be over laid with thermoplastic provided that more than 75% of the road surface is exposed, and there is no more than a single coat of paint on the remaining unexposed area. If more than one layer of paint exists, the paint is not securely anchored to the substrate, or there is less than 75% of the road surface exposed, then the paint must be thoroughly removed.
- c. All existing polyester, epoxy, or other type pavement marking paints on asphalt or concrete road surfaces must be completely removed from all road surfaces prior to the installation of thermoplastic material.

3. **Application Temperatures:** To insure optimum adhesion, the pavement and ambient air temperature shall be 50 degrees F (10 degrees C) and rising. The thermoplastic material shall be applied in a melted state at a temperature of 400 – 425 degrees F (204 – 218 degrees C). The temperature of the material within the shaping dies shall be maintained at the manufacturer's recommendations for application temperatures, but in no case shall the temperature fall below 400 degrees F (204 degrees C) or exceed 450 degrees F (232 degrees C).

Where manufacturer's application temperatures differ from those as specified, the manufacturer's temperatures shall apply upon approval of the Engineer.

4. **Line Quality:** The finished lines shall have well defined edges and be free of waviness. Pavement marking lines shall be straight or of uniform curvature and shall conform with the tangents, curves, and transitions as specified in the pavement marking standards and/or as directed by the Inspector.
  5. **Line Thickness:** The minimum thickness of the lines as viewed from a lateral cross section shall be not less than 90 mil (2.4 mm) near the edges, or less than 125 mil (3.2 mm) at the center. Drop-on glass beads shall not be included in the measurement, or if so, then appropriate allowances shall be made for the added mil thickness. A device for gauging the installed material thickness shall be furnished to the City Inspector as requested for use on the project. The gauge shall be easy to read and shall readily indicate excessive variations.
  6. **Clean Up:** The Contractor shall be responsible for removing all pavement markings material spilled upon the roadway surface or adjoining area. The Contractor shall use methods acceptable to the Engineer/Inspector for removing the spilled material.
  7. **Line Repair:** Any pavement marking which is crossed by a vehicle and tracked shall be replaced and any subsequent marking made by the vehicle shall be removed by methods acceptable to the Inspector at NO additional cost to the City.
- C. **Preformed Thermoplastic Pavement Markings:** The markings shall be applied in accordance with the manufacturer's recommendations on clean and dry surfaces.
1. **Asphalt:** The materials shall be applied using the propane torch method recommended by the manufacturer. The material must be able to be applied at ambient and road temperatures down to 32 degrees F (0 degrees C) without any preheating of the pavement to a specific temperature. The pavement shall be clean, dry and free of debris and oil or grease residue.
    - a. At temperatures below 50 degrees F (10 degrees C), the preformed thermoplastic pavement markings shall be kept as warm as possible to maintain flexibility.

- b. Remove pavement surface moisture by holding a propane torch approximately 6 inches (150 mm) above the section of asphalt using a continuous circular motion.
  - c. Heat the pavement with the torch upon placing the material to a temperature of 200 degrees F (93 degrees C) for 90 mil (2.3 mm), and up to 300 degrees F (149 degrees C) for 125 mil (3.2 mm) materials.
  - d. Immediately after the road surface has been properly preheated, position the material with exposed bead side up and heat.
  - e. Position the torch approximately 12 inches (305 mm) over the marking so the flame is extended and heat is evenly applied moving the torch in a circular motion across the marking. When the correct temperature of the marking has been reached, it will turn slightly darker or pale yellow if the material is white. Over heated or burned material shall be removed.
  - f. After the entire material section has been heated and bonded to the pavement, re-heat the perimeter of the marking and the road surface to bond the edges.
  - g. If installing reversible arrows, which do not contain a top coating of glass beads, the glass spheres shall be hand applied on the molten material.
  - h. Feather the leading edge of the pavement marking with a putty knife or bevel with the torch. Leading edges are any edge that would be susceptible to snow plow blades approaching from the direction of normal travel.
  - i. After cooling, use a putty knife to attempt to remove a portion of the material. The material shall not pry off without asphalt embedded to the underside.
2. **Concrete:** New concrete surfaces must be sandblasted to entirely remove curing compound. The same application procedure shall be used as described for asphalt pavements. However, a compatible primer sealer may be applied before application to assure proper adhesion.
  3. **Chip Seal Surfaces:** The same application procedure shall be used as described for asphalt pavements. However, exposed aggregate should be removed where the preformed thermoplastic pavement marking is to be applied.
- D. Cold Plastic Pavement Markings:** The Contractor shall furnish and install white and yellow permanent retro-reflectORIZED cold preformed plastic pavement marking material at the location shown on the plans, in conformance with the details and material specifications included herein.

The cold plastic markings shall consist of a homogeneous, extruded, prefabricated material of specified thickness and width which shall contain reflective glass spheres uniformly distributed through-out the cross-section, and shall be applied only to concrete pavement surfaces by means of an approved inlaid grinding process with pre-coated adhesive and pressure.

1. **Contractor's personnel:** It is important that the contractor's personnel be completely knowledgeable of all application requirements and procedures prior to product application. It is the responsibility of the contractor to contact the supplier of the cold plastic material if questions regarding application procedures or conditions arise.
2. **Prequalification:** Manufacturers may be required to supply a 3 sq. ft. (0.28 sq. m.) sample of each color for laboratory testing, and must comply with Paragraph 2307.4.
3. **Procedure:** This procedure explains how to apply tape to concrete surfaces only. Apply the tape according to manufacturer's instruction in conjunction with an approved inlaid grinding method.
4. **Road conditions:** It is recommended that the tape be installed as soon as practical following tape manufacturer instructions.



- a. Cold plastic pavement markings shall be inlaid by an approved grooving process into concrete pavement surfaces. Cold plastic will not be allowed on asphalt pavement surfaces whether inlaid into hot asphalt or existing asphalt surfaces. Grooving the pavement surface allows preformed pavement marking tape to better adhere by creating a fresh surface. Grooving also produces a lower profile marking by embedding the tape into the pavement surface, which helps protect the tape from snowplow damage.
  - b. The cutting head shall consist of diamond tipped cutting blades “gang stacked” 0.25 inches to 0.50 inches (6 mm to 13 mm) wide. The spacers between each blade must be such that there is less than a 10 mil (.254 mm) raise in the finished groove between the blades. Water-cooling the blades may be necessary for long line grooving.
  - c. The groove width shall be equal to the tape width plus 1 inch + 1/8 inch (25 mm + 3.2 mm). The depth of the groove shall be 75% of the tape thickness + 15%. For series 420, 60 mil (1.5 mm) tapes, the groove shall be 45 mils + 10 mils or 0.05 inch + 0.01 inch (1.25 mm + 0.25 mm). The bottom of the groove should have a smooth, flat surface. If a coarse tooth pattern is present, increase the number of blades and decrease the thickness of the spacers between the blades on the cutting head. If water-cooling is used, flush the groove immediately after grooving to clean the surface.
  - d. Clean the surface of the road and the groove using a broom and/or high-pressure air blower. If either of these methods fails to clean the road surface, then high-pressure water wash shall be used. Road surface, including the surface of the groove must be dry and all dust, dirt, debris, oil, grease and foreign material removed before applying tape. If using water-cooling to groove, the groove must be completely dry prior to tape application.
5. **Tape Application:** If there is a crack in the pavement, or if the tape is to be applied over a bridge expansion joint, manhole or utility box, lay the tape over the crack joint or fitting, then cut the tape 1 inch (2.54 cm) away from the crack or joint on each side. Apply the required surface preparation adhesive and allow to dry completely (5–10 minutes at 70 degrees F (21 degrees C), but not over 30 minutes.
  6. **Tamping:** Tamp the tape thoroughly with a tamping cart with a minimum 200 pound (90 kg) load, three times back and forth (six passes) over each part of the tape. Start in the center of the marking and work out to the edges removing any trapped air.
  7. Do not twist or turn the tamper cart on the tape
  8. Make six passes (three passes back and forth) over each part of the tape (tamping is very important)
  9. Make sure all edges are firmly adhered
  10. Application Conditions
    - a. Air temperature 60 degrees F (15.5 degrees C) and rising
    - b. Surface temperature 70 degrees F (21.1 degrees C) and rising
    - c. Overnight air temperature 40 degrees F (4.4 degrees C) the night before tape application
    - d. Pavement surface must be clean and dry. No rainfall should occur within 24 hours prior to application
    - e. Butt splices must be used; do not overlap tape ends
    - f. Traffic must be kept off of pavement surfaces coated with a surface preparation adhesive prior to tape application (follow manufacturer’s instruction regarding the use of surface preparation adhesive)

**11. Surface moisture:** Cold preformed plastic tapes will not adhere if moisture is present. Therefore, road surfaces must be dry and above the minimum required temperature for application of all tapes. If rainfall occurs within 24 hours prior to application, a surface moisture test (plastic wrap or roofing paper method as approved by the inspector) must be performed and approval obtained from the inspector. The groove must be visibly dry for a minimum of two hours prior to application. A moisture test shall be completed after the two-hour drying time to ensure no presence of moisture.

**E. Pavement Marking Paint:** The Contractor shall furnish and install white and yellow retro-reflectORIZED pavement marking paint material at the location shown on the plans, in conformance with the details and material specifications included herein.

1. The wet thickness and dry thickness of the pavement marking paint shall not be less than 15 mils (0.4 mm) and 12 mils (0.3 mm), respectively without glass beads.
2. Glass beads shall be applied uniformly over the entire length of line at the rate of 6 to 10 lbs. per gallon (0.70 – 1.20 kg per liter) of paint.
3. The gun tip shall be oriented perpendicular to the centerline to ensure that the beginning and ends of all lines are perpendicular to the centerline and not skewed.
4. The equipment shall be maintained such that the needle can be fully closed when shut as to ensure square cut lines at the beginning and ends.

**F. Epoxy Pavement Marking:** The Contractor shall furnish and install white and yellow epoxy markings at the location shown on the plans, in conformance with the details and material specifications included herein.

### 1. Equipment

- a. Use equipment that is capable of spraying both yellow and white epoxy in the manufacturer's recommended proportions. Provide equipment that call place stripes on the left and right sides, and place two lines simultaneously with either line in a solid or intermittent pattern in yellow or white. All guns must be in full view of operators at all times. If words, symbols, crosswalks, cross-hatching and stop bars are to be of epoxy resin material, equip the truck with a hand spray wand for such application. Mount the equipment on a truck of sufficient size and stability, and with an adequate power source, to produce lines of uniform dimension and prevent application failure. Provide equipment with metering devices to register the accumulated volume dispensed for each material, each day. Additionally, provide individual pressure gauges, clearly visible to the operator, for each pump used.
  - b. Provide equipment with two glass bead dispensers (double drop system) that uniformly distributes the glass beads to the surface of the epoxy pavement marking at a rate of at least 25 pounds per gallon (3 kilograms per liter). Glass beads may be applied by a pressure gun or controlled free fall.
- 2. Contractor's Personnel:** Assure that at least one employee on the project when pavement markings are being applied holds an American Traffic Safety Services Association (ATSSA) pavement marking certification.

### 3. Surface Preparation

- a. On existing pavements, remove the existing pavement markings in accordance with Section 822 of the Standard Specifications. Remove the existing markings and prepare the surface according to the manufacturer's recommendations (for the type of markings being installed).
- b. On new Portland cement concrete pavement (PCCP), use shot blasting to remove curing compounds and laitance from the surfaces to which the pavement marking will be applied. Prepare the surfaces of new concrete bridge decks the same as new PCCP.

- c. On all pavements, THOROUGHLY remove all dirt, grit, grease, grime, vegetable matter, residue of prior pavement marking application (including such adhesives or primers that may have been used in their application), and any other foreign matter from the roadway surface prior to the application of epoxy pavement markings.
4. **Alignment:** All layout required in the construction of the pavement marking is the responsibility of the Contractor. Lay out the pavement marking as detailed on the Plans. When the Plans do not provide details, submit a layout plan (conforming to the requirements of the Manual on Uniform Traffic Control Devices (MUTCD)) for the pavement markings to the Engineer for approval. Normally locate longitudinal pavement marking stripes 2 inches (50 mm) from existing longitudinal joints. Provide adequate guide marks (approximately 2 inches (50 mm) by 6 inches (150 mm) at approximately 30 to 50 ft. (10 to 15 m) intervals) for the application of the pavement markings.
5. **Pavement Marking Application**
- a. When no traffic is present, and for edge lines under any condition of traffic, a slower curing epoxy material (40 minutes) may be used. When the application is taking place under traffic, use a fast setting (10 minutes) epoxy material for center lines and skip lines.
  - b. Apply the epoxy material closely behind the cleaning procedure.
  - c. Provide the Project Engineer with a copy of the manufacturer's application instructions. Apply the epoxy pavement markings in accordance with the manufacturer's recommendations. In the absence of manufacturer's recommendations, apply the markings when the ambient and pavement surface temperatures are 50 degrees F (10 degrees C) and rising. Cease pavement marking operations when the ambient or the pavement surface temperature drops to 50 degrees F (10 degrees C).
  - d. Before mixing the components of the pavement marking material, heat the individual components to the temperature ranges recommended by the manufacturer of the material. Avoid exceeding the maximum recommended temperature at any time.
  - e. Apply the epoxy pavement marking material at a thickness of 20 mils  $\pm$  0.2 mils (500  $\mu$ m  $\pm$  50  $\mu$ m) on asphalt and PCCP. Immediately apply the glass beads to the epoxy pavement marking at the rate of 25 pounds per gallon (3 kilograms per liter) of epoxy, equally divided between the large and regular bead gradations. Apply the large beads on the first drop and the regular beads on the second.

### 2306.9 Method of Removal

Temporary pavement markings on milled surfaces scheduled to be overlaid do not have to be removed prior to performing the overlay. Permanent pavement markings installed on new asphalt surfaces shall be removed without structurally damaging the pavement or scarring the surface. The method of pavement marking tape removal shall be by a high pressure water blast method, a low pressure water and sand blast method, a steel shot blast method, or burning method. Grinding or black paint covering shall not be allowed on new pavement surfaces.

### 2306.10 Performance Measures

#### A. Thermoplastic and Aggressive Bond Thermoplastic Performance Measures

1. **Lack of specified thickness:** The full unit price bid per foot (meter) shall be withheld if lack of thickness is found more than three (3) times per 1 mile (1.6 km), or project if less than 1 mile (1.6 km) in length. Each line shall be checked a minimum of six (6) times per 1 mile (1.6 km), or project if less than 1 mile (1.6 km) in length.
2. **Lack of specified width:** Payment shall be made with penalty being equal to 25% of the unit price bid per foot (meter) for each 1/4 inch (6.4 mm) of width lacking not to exceed 100% of the unit price bid per

foot (meter) for the length of the line less than specified width. Penalty shall be imposed upon the first occurrence and every occurrence thereafter.

3. **Lack of specified length/cycle:** Payment shall be made with penalty being equal to 25% of the unit price bid per foot (meter) for each 1 inch (50 mm) of length lacking or exceeding the specified length for broken lane line and/or broken center line not to exceed 100% of the unit price bid per foot (meter) for the length of the line less than specified length. Penalty shall be imposed upon the first occurrence and every occurrence thereafter.
4. **Lack/Excess of Surface Beads or Improper Application:** The full unit price bid per foot (meter) shall be withheld for each lineal foot (meter) of material with inappropriate application rate of the surface glass beads. The same penalty shall apply if the beads are not evenly disbursed across and along a line or if the beads imbed improperly. This penalty shall be imposed for each instance that the Contractor fails to take corrective action after one warning by the Engineer.
5. **Bell ends:** The full unit price bid per foot (meter) shall be withheld for wide “bell” ends greater in length than 2 inches (50 mm). This penalty shall be for the full 6 feet (1.8 m) of a lane line or broken centerline or for no more than 6 feet (1.8 m) of a long line.

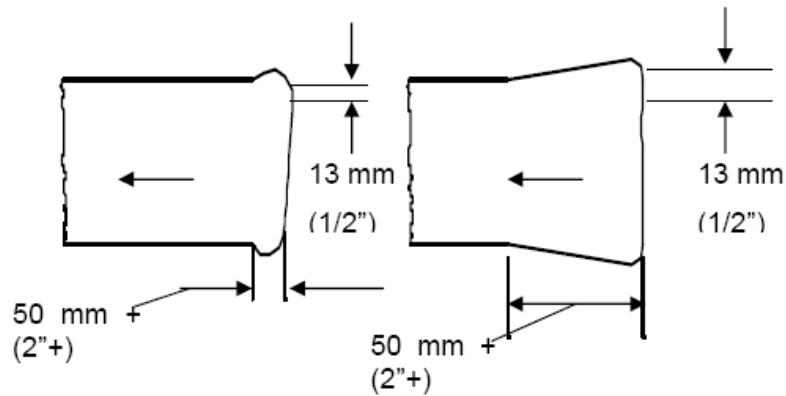

6. **Lack of Adhesion:** The full unit price bid per foot (meter) shall be withheld for 3 feet (1 meter) for each occurrence if found more than three (3) times per 1 mile (1.6 km), or project if less than 1 mile (1.6 km) in length.

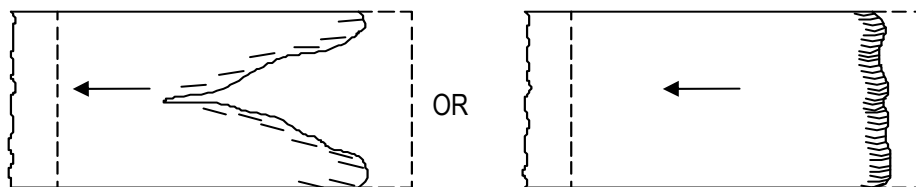

7. **Line Deviation:** A line that in the judgment of the Engineer deviates from the specified layout by an unreasonable amount shall be replaced. The Contractor shall be responsible for removal of the deviated marking material/repair of the pavement as designated by, and to the satisfaction of, the Engineer at no additional compensation.

8. **Pitted Line:** The full unit price bid per foot (meter) shall be withheld for each pit greater than 10 feet m (3.05 m) in length.

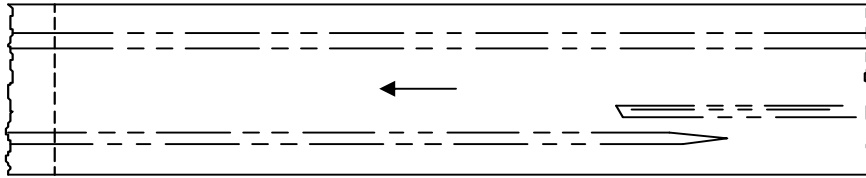

9. **Gaps in Line or Crumbly Edges:** The full unit price bid per foot (meter) shall be withheld for the entire length of the portion of any line receiving less than the required amount of thermoplastic material. This penalty shall be imposed when the Contractor fails to correct line quality after the second warning within 1 mile(1.6 km), or project if less than 1 mile (1.6 km) in length.

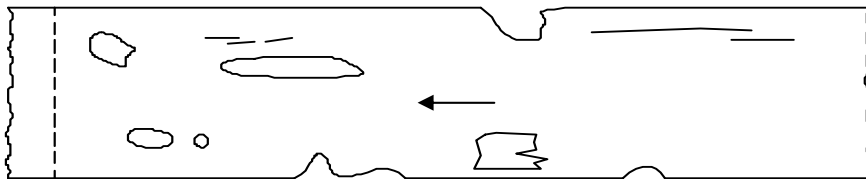

10. **Rough Line Surface:** The full unit price bid per foot (meter) shall be withheld for the entire length of the portion of any line with a rough or "burlap" surface. Penalty shall be imposed upon the first occurrence and every occurrence thereafter.

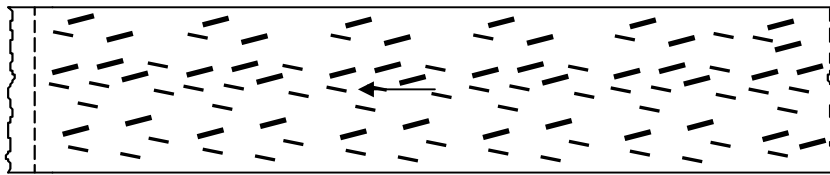

11. **Excessive Dripping between Lines:** The full unit price bid per foot (meter) shall be penalized for the length of any dribbled open space between broken lines that is not removed to the satisfaction of the Engineer before leaving the project site that work day. Penalty shall be imposed upon the first occurrence and every occurrence thereafter.

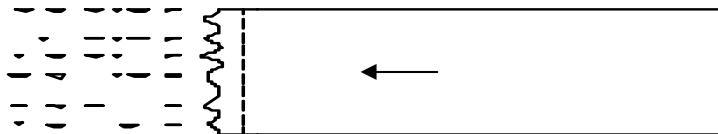

12. **Swollen Line of Excessive Width:** The full unit price bid per foot (meter) shall be penalized for swollen lines in excess of the specified width.

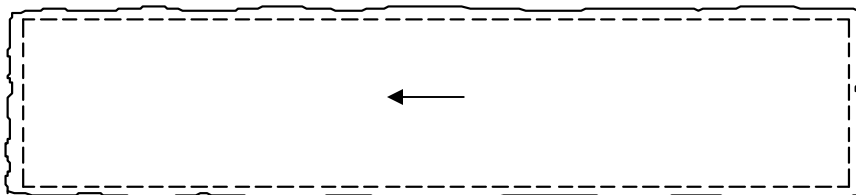

13. **Smearred Line Edges:** Fifty (50) percent of the unit price bid per foot (meter) shall be penalized for each occurrence of a length greater than 15 feet (4.6 m).

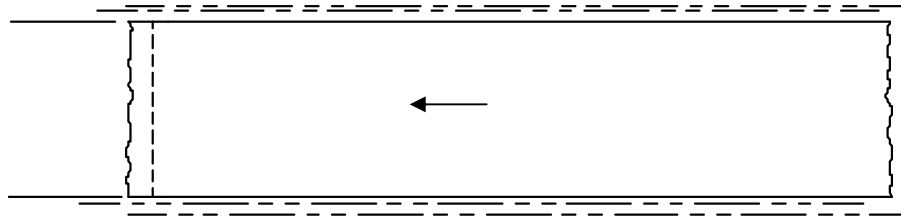

14. **Wavy Line:** The full unit price bid per foot (meter) shall be withheld for the entire length of waviness in a line caused by poor operation by the driver/operator of the application equipment. Penalty shall be imposed from the first occurrence.

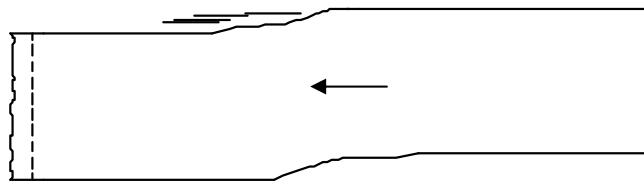

15. **Work Outside the Scope/Limits of Project:** Payment for all pavement marking work performed shall be withheld in full until the Contractor (a) removes all pavement marking material placed outside the scope/limits of the project, and (b) repairs the pavement surface as directed by and to the satisfaction of the Engineer.

**B. Preformed Thermoplastic Installation Performance Measures**

1. **Lack/Excess of Surface Beads or Improper Application:** The full unit price bid per foot (meter) shall be withheld for each lineal foot (meter) of material or per each for symbol markings with inappropriate application rate of the surface glass beads. The same penalty shall apply if the beads are not evenly disbursed across and along a line or if the beads imbed improperly. This penalty shall be imposed for each instance that the Contractor fails to take corrective action after one warning by the Engineer.
2. **Lack of Adhesion:** The full unit price bid per foot (meter) or per each for symbol markings shall be withheld for 3 feet (1 meter) for each occurrence if found more than three (3) times per 1 mile (1.6 km), or project if less than 1 mile (1.6 km) in length.
3. **Line Deviation:** A line that deviates from the specified layout by an unreasonable amount shall be replaced. The Contractor shall be responsible for removal of the deviated marking material/repair of the pavement as designated by, and to the satisfaction of, the Engineer at no additional compensation.

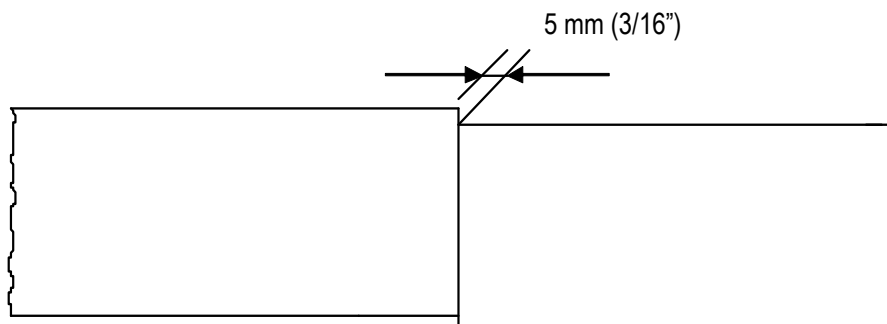

4. **Wavy Line:** The full unit price bid per foot (meter) shall be withheld for the entire length of waviness in a line caused by poor workmanship and/or application procedures. Penalty shall be imposed from the first occurrence.

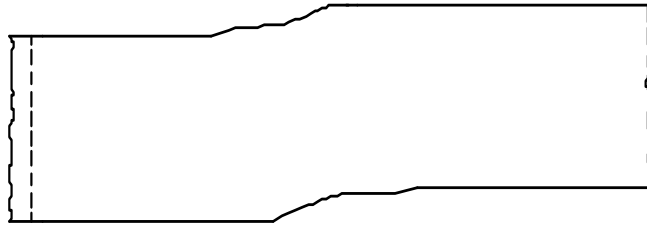

5. **Gaps between Successive Lines:** Successively placed lines that contain gaps as specified by an unreasonable amount shall be replaced. The Contractor shall be responsible for removal of the deviated marking material/repair of the pavement as designated by, and to the satisfaction of, the Engineer at no additional compensation.

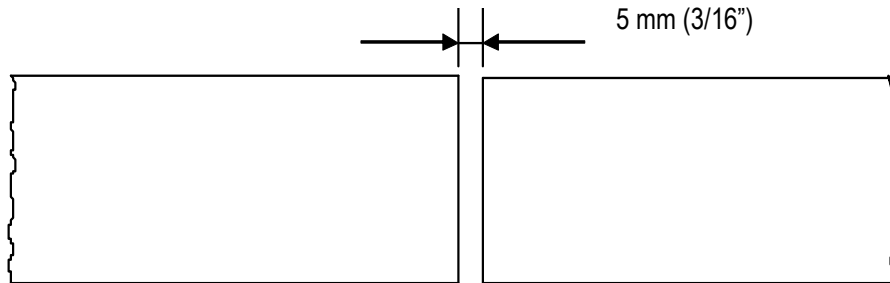

6. **Burned or Discolored Markings:** Fifty (50) percent of the full unit price bid per foot (meter) shall be withheld for each lineal foot (meter) of material or per each for symbol markings which shows signs of burning or discoloration due to prolonged application of the torch. This penalty shall be imposed for each instance that the Contractor fails to take corrective action after one warning by the Engineer.
7. **Work outside the Scope/Limits of Project:** Payment for all pavement marking work performed shall be withheld in full until the Contractor (a) removes all pavement marking material placed outside the scope/limits of the project, and (b) repairs the pavement surface as directed by and to the satisfaction of the Engineer.

**C. Cold Plastic Installation Performance Measures**

1. **Lack of adhesion:** The full unit price bid per foot (meter) shall be withheld for 3 foot (1 meter) for each occurrence if found more than three (3) times per 1 mile (1.6 km), or project if less than 1 mile (1.6 km) in length.

2. **Line Deviation:** A line that in the judgment of the Engineer deviates from the specified layout by an unreasonable amount shall be replaced. The Contractor shall be responsible for removal of the deviated marking material/repair of the pavement as designated by, and to the satisfaction of, the Engineer at no additional compensation.

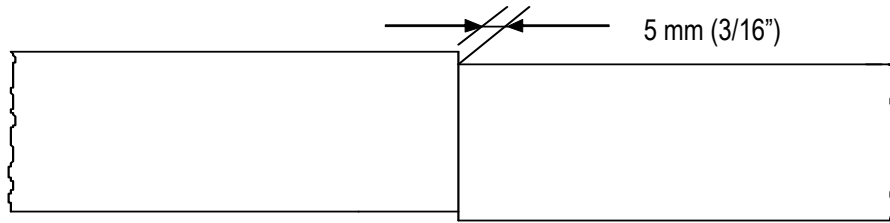

3. **Gaps between Successive Lines:** Successively placed lines that contain gaps as specified by an unreasonable amount shall be replaced. The Contractor shall be responsible for removal of the deviated marking material/repair of the pavement as designated by, and to the satisfaction of, the Engineer at no additional compensation.

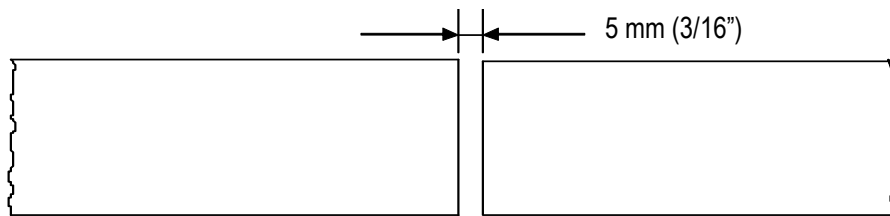

4. **Inlaid Groove Quality:** The full unit price bid per foot (meter) shall be withheld for the entire length of line that does not meet the requirements for depth of the inlaid material or for a groove that displays a coarse tooth pattern bottom that is not conducive to complete adhesion of the marking material. Penalty shall be imposed from the first occurrence.
5. **Wavy or Misaligned Line:** The full unit price bid per foot (meter) shall be withheld for the entire length of waviness caused by poor operation by the driver/operator of the grooving/installation equipment or for any misalignment in the material installed within the inlaid groove. Penalty shall be imposed from the first occurrence.

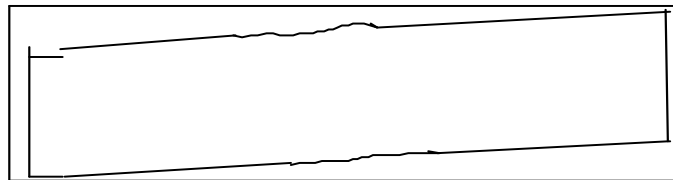

6. **Work Outside the Scope/Limits of Project:** Payment for all pavement marking work performed shall be withheld in full until the Contractor (a) removes all pavement marking material placed outside the scope/limits of the project, and (b) repairs the pavement surface as directed by and to the satisfaction of the Engineer and the local entity, if different from the Engineer.

**D. Pavement marking paint and epoxy installation performance measures**

1. **Lack of Specified Thickness:** The full unit price bid per foot (meter) shall be withheld if lack of thickness is found more than three (3) times per 1 mile (1.6 km), or project if less than 1 mile (1.6 km) in length. Each line shall be checked a minimum of six (6) times per 1 mile (1.6 km), or project if less than 1 mile (1.6 km) in length.



2. **Lack of Specified Width:** Payment shall be made with penalty being equal to 25% of the unit price bid per foot for each 1/4 inch (6.4 mm) of width lacking not to exceed 100% of the unit price bid per foot (meter) for the length of the line less than specified width. Penalty shall be imposed upon the first occurrence and every occurrence thereafter.
3. **Lack of Specified Length/Cycle:** Payment shall be made with penalty being equal to 25% of the unit price bid per foot (meter) for each 1 inch (50 mm) of length lacking or exceeding the specified length for broken lane line and/or broken center line not to exceed 100% of the unit price bid per foot (meter) for the length of the line less than specified length. Penalty shall be imposed upon the first occurrence and every occurrence thereafter.
4. **Lack/Excess of Surface Beads or Improper Application:** The full unit price bid per foot (meter) shall be withheld for each lineal foot (meter) of material with inappropriate application rate of the surface glass beads. The same penalty shall apply if the beads are not evenly disbursed across and along a line or if the beads imbed improperly. This penalty shall be imposed for each instance that the Contractor fails to take corrective action after one warning by the Engineer.
5. **Pointed Ends:** The full unit price bid per foot (meter) shall be withheld for pointed ends. This penalty shall be for the full 6 feet (1.8 m) of a lane line or broken centerline or for no more than 6 feet (1.8 m) of a long line.

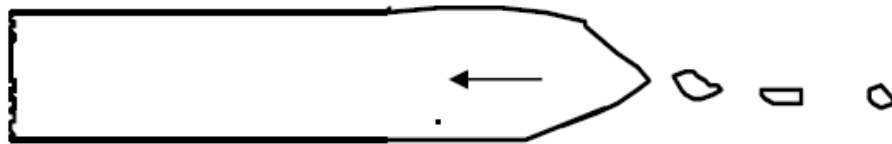

6. **Skewed Ends:** The full unit price bid per foot (meter) shall be withheld for skewed ends. This penalty shall be for the full 6 feet (1.8 m) of a lane line or broken centerline or for no more than 6 feet (1.8 m) of a long line.

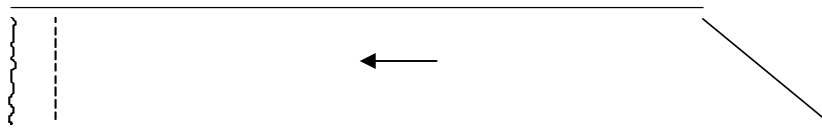

7. **Line Deviation:** A line that in the judgment of the Engineer deviates from the specified layout by an unreasonable amount shall be replaced. The Contractor shall be responsible for removal of the deviated marking material/repair of the pavement as designated by, and to the satisfaction of, the Engineer at no additional compensation.
8. **Excessive Dripping between Lines:** The full unit price bid per foot (meter) shall be penalized for the length of any dribbled open space between broken lines that is not removed to the satisfaction of the Engineer before leaving the project site that work day. Penalty shall be imposed upon the first occurrence and every occurrence thereafter.

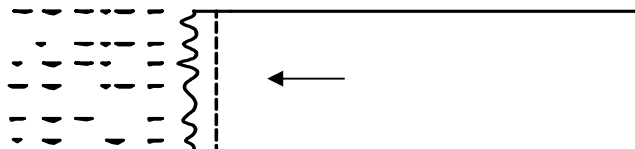

9. **Wavy Line:** The full unit price bid per foot (meter) shall be withheld for the entire length of waviness in

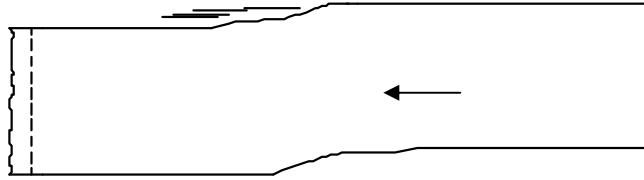

a line caused by poor operation by the driver/operator of the application equipment. Penalty shall be imposed from the first occurrence.

10. **Non-Uniform Thickness:** The line shall be uniform thickness across the entire cross section of the line with well-defined edges. Heavy inner thickness and thin edges or vice-versa will not be accepted. The full unit price bid per foot (meter) shall be withheld for lines that are not of uniform thickness. Penalty shall be imposed from the first occurrence.

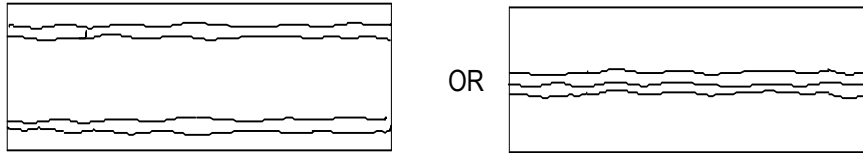

11. **Work outside the Scope/Limits of Project:** Payment for all pavement marking work performed shall be withheld in full until the Contractor (a) removes all pavement marking material placed outside the scope/limits of the project, and (b) repairs the pavement surface as directed by and to the satisfaction of the Engineer.

#### 2306.11 Method of Measurement

Pavement Markings will be measured by one of the following:

- A. Per linear foot (linear meter) of line. Skip lines are paid based upon length of marked section; 1 foot of a dual line is paid for at two unit feet bid.
- B. Per each symbol.

#### 2306.12 Basis of Payment:

Pavement Markings will be paid for by one of the following:

- A. Contract unit bid price
- B. Contract lump sum bid price

## SECTION 2307 FENCING

### 2307.1 Summary

This section governs the installation, and removal of fence.

### 2307.2 Referenced Standards

The following standards are referenced directly in this section. The latest version of these standards shall be used.

**Missouri Standard Specifications for Highway Construction**

Section 1043 Fence Materials

Section 607 Chain – Link Fence

**Kansas Standard Specifications for State Road and Bridge Construction**

Section 828 – Fencing

Section 1620 – Material for Fencing

**Midwest Concrete Industry Board (MCIB)**

Section 4.1 (Use Latest Revision Adopted)

**2307.3 Materials:**

- A. All materials used for the installation of a permanent chain link fence shall be new material conforming to:

**Missouri Projects:** Section 1043 of the Missouri Standard Specification for highway construction except concrete for posts shall be MCIB Mix No. A543-1-4-0.479 or approved equal.

**Kansas Projects:** Section 1620 of the Kansas Standard Specifications for State Road and Bridge Construction except concrete for posts shall be MCIB Mix No. A543-1-4-0.479 or approved equal.

- B. All material used for the installation of permanent decorative fence shall be new material as specified or as shown on the plans or match the existing fence.

**2307.4 Construction Details:**

- A. **Removal:** Existing fence shall be removed as specified or as shown on the plans or as directed by the Engineer. Removed fencing may be used for temporary fencing only with the Engineer’s approval.
- B. **Chain-Link Fence.** Chain-Link Fence shall be installed at the locations shown or as directed by the Engineer in accordance with Section 607 of the Missouri Standard Specifications For Highway Construction, or Section 828 of the Kansas Standard Specifications for State Road and Bridge Construction as applicable, except that the bottom of the fabric shall be not more than 1 ½ inches (38 mm) above the finished ground line. All residential fence shall have a top rail and all edges of fence fabric shall be knuckled.
- C. **Decorative Fence:** Decorative shall be installed at the locations shown or as directed by the engineer in accordance with the manufactures instructions and recognized industry standards or as directed by the Engineer.

**2307.5 Measurement and Payment**

- A. **Fence:** Fence shall be measured along the slope of the fence to the nearest linear foot (.05m). Vehicle gates shall not be included in this measurement. .
- B. **Gates:** Gates shall be measured per each for the size and type specified.
- C. **Temporary Fence:** Temporary fence will be measured by one of the following.
  - \_ No measurement made.
  - \_ Per foot measured along the slope to the nearest linear foot
- D. **Fence Removal:** Fence removal will be measured by one of the following.
  - \_ No measurement made.
  - \_ Per linear foot to nearest foot.

- E. **Payment.** Fence of the respective type and size will be paid for as listed on the Bid Form – Unit Prices. There will be no separate payment for pedestrian gates; they are subsidiary to the fence pay item.

## SECTION 2308 STEEL BEAM GUARDRAIL

### 2308.1 Scope

This section governs furnishing materials for and installation of steel beam guardrail.

- A. **Steel Posts:** All posts, terminal post connectors, and steel blocks for guardrail shall be formed from a structural steel meeting the requirements of ASTM A-36, *and shall be galvanized in accordance with ASTM A-123.*
- B. **Guardrail and Hardware:** All guardrail and hardware shall conform to the requirements of AASHTO M-180 Class A, Type 1. Hardware shall be galvanized in accordance with ASTM A-153. Guardrail shall be galvanized with a minimum of 1.80 ounces of Zinc per sq. ft. All Zinc shall be "Prime Western" grade or better

### 2308.2 Erection:

- A. **Setting Posts:** Posts shall be set to the depth and spaced at the intervals shown on the construction plans or standard drawings. They shall be set vertical and true to line and grade. Steel posts may be driven by a power hammer or may be set in dug or bored holes of a size sufficient to permit thorough compacting of the backfill around the post. The backfill material shall be dry sand, placed in layers not exceeding 12 inches (30.5 cm) in thickness to height 12 inches (30.5 cm) below the finished grade. After erecting and adjusting the rail to true line and grade, the sand backfill shall be compacted by flooding. The final 12 inches (30.5 cm) of backfill consisting of suitable earth material shall then be compacted in six inch (15.24 cm) lifts. Any "mushrooming" of the top of a post shall be removed and damaged spelter coating on posts shall be repaired by the zinc alloy stick method while the surface is heated to approximately 600° F (315° C). Other methods of repairing the spelter coating shall receive prior approval of the Engineer.
- B. **Erecting Guardrail:** Bolt holes shall be shop punched. Field punching, reaming and drilling will not be permitted. Guardrail beams shall be spliced, only at posts by lapping in the direction of traffic, using the required number of splice bolts. Beams for twisted turned down terminal sections may be either field or shop twisted. Sufficient twist shall be introduced such that the beam shall retain the required shape in a relaxed condition. Beams to be erected on a radius of 150 feet (45.7 m) or less shall be shop-curved as shown on the plans. Each end of every installation of guardrail shall have an end, bridge anchor, or terminal section of the design and type shown on the construction plans or standard drawings. They shall be of the same material and shall be galvanized in accordance with the requirements for the guardrail beam. Galvanized rail shall be handled in a manner to avoid damage to the galvanized coating. Any sections of rail, end sections or terminal sections on which the spelter coating has been bruised or broken shall be rejected, or may, with the prior approval of the Engineer, be repaired by the method prescribed for repairing damaged spelter coating of steel posts.

### 2308.3 Measurement and Payment

Steel beam guardrail will be measured from center of terminal post to center of terminal post per linear foot and quarter part thereof. Payment will be made at the contract unit or lump sum bid price. There will be no separate payment for terminal end sections except when specified in the project manual.

## SECTION 2309 MEASUREMENTS AND PAYMENT

### 2309.1 Summary

This section governs the method of measurement and the basis of payment for furnishing all labor, equipment, tools, and materials and for the performance of all related work necessary to complete any construction covered in Section 2300.

### 2309.2 General

Unless specifically altered by the Special Provisions, the methods of measurement and payment shall be as specified in each section herein, and as listed in the Proposal.

### 2309.3 Measurement

The Engineer or his representative will measure the work for payment. The method of measurement and computations used in determination of quantities of work performed will be those methods generally recognized as conforming to good engineering practice.

Items not listed in the Proposal: There shall be no measurement or separate payment for any item of work not specifically identified and listed in the Proposal and all costs pertaining thereto shall be included in the contract unit prices for other items which are listed in the Proposal.

### 2309.4 Measurement and Payment Summary Table

Item Description	Ref. Section	Method of Measurement	Basis of Payment
Sidewalks	2301	1 sq. ft. (0.1 sq. m.)*	Unit Bid Bid
Sidewalk Ramps	2301	1 sq. ft. (0.1 sq. m.)* Each	Unit Bid Price Lump Sum
Concrete Driveways	2301	1 sq. ft. (0.1 sq. m.)*	Unit Bid Price
Bicycle/Pedestrian Paths (PCC)	2301	1 sq. ft. (0.1 sq. m.)*	Unit Bid Price
Temporary Asphalt Sidewalks	2302	0.1 ton (0.1 metric ton) 1 sq. ft. (0.1 sq. m.)*	Unit Bid Price
Asphalt Driveways	2302	0.1 ton (0.1 metric ton) 1 sq. ft. (0.1 sq. m.)*	Unit Bid Price
Bicycle/Pedestrian Paths (Asphalt)	2302	0.1 ton (0.1 metric ton) 1 sq. ft. (0.1 sq. m.)*	Unit Bid Price
Rock Blanket	2303	1 sq. yd. (0.1 sq. m.)* 1 ton (1 metric ton)	Unit Bid Price
Concrete Paver Stones	2304	1 sq. ft. (0.1 sq. m.)**	Unit Bid Price
Maintenance of Traffic	2305	Each device listed per day	Unit Bid Price Lump Sum
Pavement Markings	2306	1 lin. ft. (1 lin. m.) each	Unit Bid Price Lump Sum
Fencing	2307	1 lin. ft. (1 lin. m.) Each	Unit Bid Price Lump Sum
Steel Beam Guardrail	2308	1 lin. ft. (1 lin. m.) Each	Unit Bid Price Lump Sum

\*Items measured by area shall be listed with the specified depth of material indicated.

\*\* Concrete Paver Stones includes PCC base course