

**DIVISION II
CONSTRUCTION AND MATERIAL SPECIFICATIONS
SECTION 2100 GRADING AND SITE PREPARATION**

APPROVED AND ADOPTED THIS 15th DAY OF FEBRUARY, 2017
Revised May 17, 2019 (See underlined text)

**KANSAS CITY METROPOLITAN CHAPTER
OF THE AMERICAN PUBLIC WORKS ASSOCIATION**

TABLE OF CONTENTS

SECTION 2101 CLEARING, GRUBBING, AND SITE PREPARATION	1
2101.1 Scope	1
2101.2 Referenced Standards	1
2101.3 Definitions.....	1
2101.4 Construction	2
SECTION 2102 GRADING	5
2102.1 Scope	5
2102.2 Definitions.....	5
2102.3 Construction	7
2102.4 Excavation, Trenching, And Backfilling For Pipe And Structures.....	9
2102.5 Undergrading.....	16
2102.6 Embankment	16
2102.7 Finishing.....	18
2102.8 Cleanup.....	18
SECTION 2103 MEASUREMENT AND PAYMENT	18
2103.1 General.....	18
2103.2 Method of Measurement	19
2103.3 Basis of Payment	20
SECTION 2104 BACKFILL DETAILS.....	21

May 17, 2019 - Section 2102.2.E.6: Revisions made to strengths and unit weights of flowable fill.

SECTION 2101 CLEARING, GRUBBING, AND SITE PREPARATION

2101.1 Scope

This section governs the furnishing of all labor, materials, and equipment for the performance of all clearing, grubbing, and demolition within the limits of work as shown on the Plans and in accordance with the Standard Drawings, the Specifications, and the Special Provisions.

2101.2 Referenced Standards

The following standards are referenced directly in this section. The latest version of these standards shall be used. If conflicting standards are referenced, the more stringent standard shall apply.

APWA

2150	Erosion and Sediment Control
2201	Subgrade Preparation
2203	Aggregate Base
2307	Fencing
2700	Structures

ASTM

ASTM C 150	Standard Specification for Portland Cement
ASTM C 260	Standard Specification for Air-Entraining Admixtures for Concrete
ASTM C 33	Standard Specification for Concrete Aggregates
ASTM C 494	Standard Specification for Chemical Admixtures for Concrete
ASTM C 618	Standard Specification for Coal Fly Ash and Raw or Calcined Natural Pozzolan for Use in Concrete
ASTM D 698	Standard Test Methods for Laboratory Compaction Characteristics of Soil Using Standard Effort
ASTM C 1602	Standard Specification for Mixing Water Used in the Production of Hydraulic Cement Concrete
ASTM D 4318	Standard Test Methods for Liquid Limit, Plastic Limit, and Plasticity Index of Soils
ASTM D 4832	Standard Test Method for Preparation and Testing of Controlled Low Strength Material (CLSM) Test Cylinders

Kansas Department of Transportation

Standard Specifications for State Road and Bridge Construction, 2015 Edition
KDOT AB-3 Aggregate Base

Missouri Highways and Transportation Commission

Missouri Standard Specifications for Highway Construction, 2011 Edition
MoDOT Types 1 or 5 Aggregate Base

2101.3 Definitions

The following terms have the meanings indicated:

- A.** Clearing: Clearing shall consist of removing all vegetative matter such as trees, brush, down timber and other objectionable materials found on or above the surface of the site. It shall include removing buildings, fences, lumber, waste dumps and trash and the salvaging of such materials as may be specified and disposing of the debris.

The Contractor shall not occupy any portion of the Project Site prior to the date established in the Notice to Proceed without prior approval of the Owner.

- B.** Grubbing: Grubbing shall consist of removing and disposing of all vegetative matter such as stumps, roots, buried trees and brush encountered below the surface of the ground or subgrade, whichever is lower, which have not been included in Section 2101.2.A entitled "Clearing".

Trees to be removed shall be completely removed, including stump and large roots, unless such removal may result in damage to existing utilities. In that event, trees shall be sawn off not more than four (4) inches above the ground and the stump shall be removed to twelve (12) inches below finish grade.

In all cases of grubbing, the vegetative matter shall be removed to a minimum depth of 12 inches below ground line or subgrade, whichever is lower, except as provided in Section 2101.3.C.

When deleterious materials are encountered below ground line which may be detrimental to the proposed improvement, these materials shall be removed to a depth necessary to provide adequate support for the proposed improvement.

- C.** Site Preparation: Site Preparation shall consist of all initial preparation work for the project site and includes, but is not limited to: steps to minimize site disturbance of existing vegetative, structures and private property; phasing and sequence construction activities into logical work zones; installation of erosion control measures; topsoil stripping, stockpiling and spreading; identifying haul roads, construction entrances and/or exits, construction parking areas; mailbox and fencing adjustments; etc. All site preparation shall be considered incidental unless such site preparation is listed separately in the Contract Documents.

- D.** Demolition and Removal: This work shall consist of demolishing, removing, and disposing of all structures and improvements within the construction limits unless included in other items of work as shown on the Plans or in the Special Provisions. This work shall apply to all structures and improvements, whether on, above or below the surface of the ground or subgrade.

Demolition and removal shall include but not be limited to items such as buildings, drainage structures, pipes, pavements, fences, retaining walls, guard rails, and signs.

Items such as fences, drainage structures, streetlighting, signing and guard rails shall be salvaged and relinquished to the appropriate owner or relocated, where indicated on the Plans.

Relocation of signs, fences, guardrails, etc. shall be considered incidental to removal work except where such relocation is listed separately in the Contract Documents.

All pipes which are to be abandoned shall be removed unless otherwise shown on the Plans or approved by the Engineer.

- E.** Trees: Vegetative growth 6 inches in diameter and larger, measured 3 feet above ground shall be classified as a tree.
- F.** Brush: Vegetative growth less than 6 inches in diameter, measured 3 feet above ground shall be classified as brush.

2101.4 Construction

- A. Erosion and Sediment Control: Comply with Section 2150 Erosion and Sediment Control.
- B. Limits of Work: The limits for clearing, grubbing, and demolition shall extend to the construction limits unless otherwise shown on the Plans. Contractor shall do all clearing necessary for performance of their work and shall confine their operations to that area provided through easements, licenses, agreements and rights-of-way. The Contractor's entrance upon any lands outside of that area provided by easements, licenses, agreements or public rights-of-way, shall be at the Contractor's sole liability.

In the event construction limits have not been indicated on the Plans, the limits for clearing, grubbing, and demolition shall not extend beyond the limits of the Owner's property, right-of-way, or easements.

- C. Protection of Greenery, Existing Structures and Private Facilities: The Plans will designate trees, shrubs or other plants that are to be saved and the Contractor will take necessary steps to protect this greenery. All reasonable effort shall be made to save as many trees as possible. If trees can be saved by trimming, this shall be done in accordance with acceptable pruning practices. Trees may be pruned, upon prior approval of the Engineer, but only in accordance with the best practices of arboriculture in respect to the individual species with due regard to their natural form and growth characteristics.

Small Plants and Flowers: At least two weeks prior to the start of construction, property owners shall be notified by the Contractor of the proposed starting date. The purpose of this notification is so that the property owners can remove any small plants or flowers that they, the property owners, desire to save.

Existing structures within or adjacent to the construction limits that are not to be removed or demolished, shall be protected by the Contractor during their construction. Any private facilities such as house sewer laterals which are disturbed or damaged by the Contractor's work, shall be repaired by the Contractor prior to the close of the work day. This repair shall be made in a manner sufficient to restore utility service to that property. Restoration of utilities damaged by the Contractor shall be restored as directed by the utility company at no additional cost to the Owner. Unless otherwise provided in Basis of Payment no separate or additional payment will be made for any work in connection with removal, relocation or restoration of obstructions and existing facilities.

- D. Surface Obstructions: Natural obstructions, existing facilities and improvements encountered during site preparation shall be removed, relocated, reconstructed or worked around as herein specified. Care shall be used while performing site preparation work adjacent to any facilities intended to remain in place. Except as otherwise specified, the Contractor shall be responsible for any damage to existing facilities and improvements and any repairs required shall be promptly made at the Contractor's expense. Waste materials shall be disposed of in a satisfactory manner off the work site.
- E. Surface Obstructions for Pipeline Trenches: Sidewalks, curb and gutter, drainage structures and similar obstructions shall be tunneled under if tunneling is best suited, otherwise the obstruction shall be cut in straight lines or removed to the nearest construction joint if located within five feet of the center-line of the trench. In no case shall the joint or line of cut be less than one foot outside the edge of the trench. Surface obstructions removed to permit construction shall be reconstructed as specified and to the dimensions, lines and grades of original construction.
- F. Embankment Areas: When undisturbed stumps and roots are encountered where the fill depth will exceed 3 feet, the stumps and roots may be left in place provided they do not extend more than 3 inches above the original ground line.

- G. Borrow Areas: All stumps, roots and other objectionable matter shall be removed from the borrow material used for embankment or fill. The borrow area shall be left in a well-drained and smooth condition.
- H. Backfilling the Site: All trenches, holes, pits, and basement areas resulting from the operations of clearing, grubbing, demolition and removal on the site, shall be backfilled with suitable material placed and compacted in conformance with applicable sections of these specifications.
- I. Disposal of Materials: All materials with the exception of those which are designated for salvage or which are used in the embankment in conformance with this specification, shall become the Contractor's property and shall be disposed of by Contractor, outside the project limits at a site as approved by the Owner, unless otherwise indicated on the Plans. The disposal of waste and excess excavated materials, including hauling, handling, grading, and surfacing shall be a subsidiary obligation of the Contractor.
- J. Hazardous Materials
 - 1. In the event hazardous waste as defined by the Resource Conservation and Recovery Act of 1976 (PL94-580) are encountered, work shall be halted and the Owner shall be notified. Work shall be resumed only after the Owner notifies the Contractor. Regulation of removal, handling and disposal of hazardous wastes is the responsibility of Federal and State agencies.
 - 2. All other items classified as "hazardous" shall be disposed of in accordance with the applicable codes. The Contractor shall refer to Section 2150 entitled "Erosion and Sediment Control".
- K. Items to be Left in Place: In removing items such as concrete pavements, curbs, curb and gutter, sidewalks and similar objects where portions of these objects are to be left in place they shall be removed to an existing joint or a new joint, sawed to a minimum depth of 2 inches or ¼ the slab thickness, whichever is greater. This joint shall be to true line and vertical face. Sufficient portions of such items shall be removed to provide the proper grade and connection to the new work.
- L. Mailboxes: Mailboxes shall be maintained in the manner that the Postal Service requires to prevent interruption of mail delivery.
- M. Fences: Refer to Section 2307 for fencing.
- N. Property Pins: The Contractor shall preserve all property corners, pins or markers. In the event any property corners, pins, or markers are removed by the Contractor, such property points shall be replaced at the Contractor's expense and shall be reset by competent surveyors properly licensed to do such work. In the event such points are section corners or Federal land corners, they shall be referenced and filed with the appropriate authority.
- O. Subsurface Obstruction of Pipeline Trenches: Where existing utilities and service lines are to be encountered, the Owner thereof shall be notified by the Contractor at least 48 hours (not including weekends and/or holidays) in advance of performing any work in the vicinity. All excavation, pipeline installation and backfilling work in the vicinity of such utilities shall be accomplished in the manner required by the respective Owner and, if requested, under their direct supervision. The Contractor shall be responsible for any and all damages to a public or private utility that may occur as the result of the construction.

The Contractor shall make a reasonable effort to ascertain the existence of obstructions and shall locate obstructions by digging in advance of machine excavation where definite information is not available as to their exact location. Where such facilities are unexpectedly encountered and damaged, responsible officials and

other affected utilities shall be notified and arrangements made for the prompt repair and restoration of service.

SECTION 2102 GRADING

2102.1 Scope

This section governs the furnishing of all labor, materials, and equipment required to excavate, place, remove, dispose or compact materials encountered within the limits of the project as shown on the Plans and in accordance with the Standard Drawings, the specifications, and the Special Provisions.

2102.2 Definitions

The following terms have the meanings indicated:

- A.** Grading: Grading as used herein shall mean the performance of all excavation, embankment, and backfill in connection with the construction of all improvements.
- B.** Excavation: Excavation is defined as the removal of materials from the construction area to the lines and grades shown on the Plans and includes trenching for pipelines, utilities, and structures.
 - 1. Unclassified Excavation: Unclassified excavation is defined as the removal of all material encountered regardless of its nature. All material excavated will be considered as Unclassified Excavation unless otherwise specified in the Contract Documents.
 - 2. Rock Excavation: Rock excavation is defined as the removal of all rock ledges 6 inches or more in thickness, and detached rock or boulders having a volume of more than 1 ½ cubic yards and shale occurring in its natural state, hard and un-weathered.
 - a. A rock ledge is defined as a continuous body of rock which may include thin interbedded seams of shale or other soft materials less than 12 inches thick. The vertical limit of each ledge shall be defined by interbedded seams of soft materials 12 inches or more in thickness. The beds of soft interbedded material 12 inches or more in thickness shall not be included in the measurement for “Rock Excavation” but shall be included in the measurement for “Earth Excavation”.
 - b. The following items shall not be considered as rock excavation: soft or disintegrated rock or flowable backfill (CLSM) which can be removed with a pick or digging machine; loose, shaken or previously blasted rock; broken stones and rock which may fall into the trench from outside the limits of excavation.
 - c. When solid rock (including non-diggable flowable backfill (CLSM)) is unexpectedly discovered, the Contractor shall notify the Owner.
 - 3. Earth Excavation: Earth excavation is defined as the removal of all material not defined as rock.
 - 4. Trench Excavation: Trench excavation is defined as excavation to the width and depth as necessary to lay the pipe to the grade line as indicated on the Plans and in the specifications.
 - 5. Tunneling, Boring and Jacking: Includes all underground horizontal excavations necessary to install the pipeline to the grade line as indicated on the Plans and in the specifications.

- C. Trench Foundation: The area at the bottom of the excavation shall be composed of a stable material capable of supporting the placement of bedding material, pipe, or structures.
- D. Unstable Foundation: Materials encountered in the bottom of the trench deemed as unsuitable by the Engineer to afford a sufficiently stable pipe foundation.
- E. Flowable Backfill / Controlled Low Strength Material (CLSM): A mixture of portland cement, fly ash (optional), fine aggregate, water, and admixtures (as approved by the Engineer) proportioned to a consistency to fill voids without vibration. Flowable Backfill (CLSM) shall consist of:
1. Cement: The portland cement shall conform to ASTM C 150, Type 1 or Type II.
 2. Fly ash: Fly ash, when used, shall conform to the requirements of ASTM C 618 Class C or F.
 3. Fine Aggregate: Fine aggregate shall conform to ASTM C 33.
 4. Mixing Water: Mixing water shall conform to ASTM C 1602.
 5. Admixtures: Air entrainment, when used, shall conform to ASTM C 260. Water reducing admixtures, when used, shall conform to ASTM C 494. All other admixtures shall only be used when approved by the Engineer.
 6. Other materials: Proposed replacement or supplementary materials shall be approved by the Engineer and in conformance with current NRMCA or ACI guidelines for CLSM.

Flowable Backfill (CLSM) compressive strength testing results are required for approval of mix design prior to placement of flowable backfill. Compressive tests are to be conducted at 7 and 28 days in accordance with ASTM D 4832. CLSM shall have a minimum and maximum 28-day design compressive strength of 50 psi and 125 psi, respectively. The unit weight of the CLSM shall be a minimum of 120 lbs. per cubic foot (pcf). All tests necessary for determining conformance with the requirements specified herein will be at the Contractor's expense.

- F. Bedding: The placing and compacting of the aggregate material above the stable foundation and below the pipes or structures.
- G. Embedment: The placing and compacting of approved material surrounding the pipe up to a maximum of 12-inches above the top of pipe.
- H. Embankment or Backfill: The placing and compacting of approved material in the construction areas to the lines and grades shown on the Plans.
1. Unsuitable Material: Muck, frozen material, organic material, top soil, or rubbish. Rock with a maximum dimension greater than 24 inches is also defined as unsuitable. Top soil is unsuitable for embankment and backfill, but may be used as the surfacing for graded areas to be seeded or sodded (see Section 2400).
 2. Suitable Material: Suitable material is defined as entirely imperishable with that portion passing the No. 40 Sieve having a liquid limit not exceeding 40 and a plastic index not exceeding 25, when tested in accordance with ASTM D 4318.

- a. Rock Embankment: Material for rock embankment shall be free of unsuitable material and shall contain, by volume, greater than 10 percent rock or gravel having a maximum dimension greater than 3 inches but not greater than 24 inches.
 - b. Earth Embankment: Material for earth embankment shall be free of unsuitable material and shall, contain by volume, less than 10 percent rock or gravel having a maximum dimension greater than 3 inches.
3. Pipe Backfill: Pipe backfill materials shall be furnished and installed to complete the work shown on the Plans or as called for in the Contract Documents.
- a. Select Earth Backfill Material: Select earth backfill shall be finely divided job excavated material free from debris, organic matter, rocks larger than one (1) inch and/or frozen materials.
 - b. Other Earth Backfill: Other backfill may be job excavated material free from debris and organic matter. No rock greater than three-inches in diameter shall be placed in any trench excavation as backfill unless approved by the Engineer.
 - c. Aggregate Backfill Material: Approved material meeting ASTM C33 requirements and the specified gradations.
 - d. Flowable Backfill (CLSM): See Section 2102.2.E.
- I. Borrow: Approved material excavated from an area outside of the project limits and required for the construction of the embankment.
- J. Waste: Waste is defined as excavation material not used in the embankment and disposed of outside of the embankment areas.
- K. Structures: Used herein refers to culverts, storm sewer and/or sanitary appurtenances, and similar construction. See Section 2700 for other structures.

2102.3 Construction

- A. The Contractor shall adhere to any and all statutes regarding the notification of utilities prior to beginning any work within public right-of-way. The relocation and/or protection of any utility that is shown on the Plans, that lies within a utility easement and is endangered by this construction shall be the responsibility of the Contractor.
- B. The Contractor shall make every reasonable effort to protect private facilities. These facilities may not be shown on the Plans. When these facilities are disturbed or damaged by the work, the Contractor shall make necessary arrangements for repairs to the facilities for continuous service prior to the close of that work day.
- C. It shall be the responsibility of the Contractor to protect all property lot corners and control monumentation. Should it be necessary to disturb any such monument, whether stake, pin, bar, disk, box, or other, it remains the responsibility of the Contractor to reference such markers prior to removal, reset them, and file such relocations or monumentation documents as the law may require. Any such references, removal, replacement and certification of monuments shall be performed by a registered licensed surveyor. A copy of all such certification documents shall be provided to the Owner prior to final payment. Any monument destroyed or improperly reset by the Contractor may be replaced by the Owner to the standards required by law at the expense of the Contractor.
- D. Grading, excavation, and backfilling for all improvements, shall be made to the lines, grades, and cross sections indicated by the Plans.

- E.** In addition, to any erosion control measures shown on the Plans, the Contractor shall schedule and conduct their operation in such a manner and shall provide any necessary control facilities to protect downstream and adjacent properties from pollution, sedimentation, or erosion caused by the grading operations. Any pollution or damage occurring shall be the responsibility of the Contractor. See Section 2150 Erosion and Sediment Control.
- F.** During construction, the graded area shall be maintained by the Contractor in such condition that it will be well drained at all times. Roadway ditches, channel changes, inlet and outlet ditches and other ditches in connection with the roadway shall be cut and maintained to the required cross section. All drainage work shall be performed in proper sequence with other operations. All ditches and channels shall be kept free of debris or obstructions not identified in the erosion control plan.
- G.** All suitable material removed by excavation shall be used as far as practicable in the formation of embankment as required to complete the work. The Contractor shall sort all excavated material and stockpile when necessary, so as to provide suitable materials for embankments.
- H.** After removal of the roadway excavation material to the required section, all material between lines 1 foot outside of the curbs and within the top 6 inches of the subgrade shall be compacted to 95 percent of maximum density for the material as defined in Section 2102.6.F.
- I.** Rock encountered within the full width of the roadway, toe of slope to toe of slope, shall be undergraded to an elevation of 6 inches below the finished subgrade elevation. Care shall be taken to avoid overshooting when blasting. Rock shall be removed in such a manner as to leave no excessive water pockets in the surface.
- J.** **Blasting:** When blasting is permitted by the Engineer, the Contractor shall use the utmost care to protect life and property. The Contractor shall obtain any required permits from the agency having site jurisdiction and shall comply with all laws, ordinances, and the applicable safety code requirements and regulations relative to the handling, storage and use of explosives and protection of life and property, and he shall be responsible for all damage caused by his or his subcontractor's operations.
 - 1. The Contractor shall provide insurance as required by the Contract Documents before performing any blasting. The governing agency shall be notified at least 24 hours before blasting operations begin.
- K.** **No Blasting Areas:** No blasting of any kind for rock excavations or any other purpose will be allowed unless noted otherwise on the Plans or permitted by the Engineer.
- L.** Areas of undergrading or overbreakage in rock between lines 1 foot outside of the curbs shall be backfilled with spalls, rock fragments or a granular type material. Backfill materials shall have a plasticity index not to exceed 10 and a gradation such that at least 50 percent of the material will be retained on the No. 4 Sieve.
- M.** **Cribbing and Sheeting:** The Contractor shall furnish, install, and maintain such sheeting, bracing, and other components, as may be required to support any excavation and to prevent any movement which could in any way injure or delay the work or endanger adjacent pavement, building, or other structures. Care shall be taken to prevent voids outside of the sheeting, but if voids are formed they shall be immediately filled and consolidated.

For the purpose of preventing injury or property damage, Contractor may leave in place all sheeting or bracing, and other items to be embedded in the backfill of the trench. No sheeting or bracing, however, shall be left in

place within 5 feet of the surface without the written permission of the Engineer.

2102.4 Excavation, Trenching, And Backfilling For Pipe And Structures

A. Dewatering of Excavation

1. The Contractor shall maintain a dry and stable excavation, obtain necessary permits, and provide for the proper method of discharging water from the work site at all times until installation is completed.
2. The Contractor shall not allow hydrostatic pressure flotation or other adverse effects to cause damage to the structure or pipeline.
3. Proper dewatering techniques are the Contractor's responsibility. All work performed by the Contractor that is adversely affected by his/her failure to adequately dewater trenches will be subject to rejection by the Engineer. The Contractor shall repair and/or replace affected structures or pipelines.
4. The Contractor shall remove any water that may accumulate or be found in the trenches and other excavations made as part of the work.
5. Grading shall be done to prevent surface water from flowing into trenches or other excavations, and to maintain the flow of water in natural watercourses on or adjacent to the site. Any water accumulating in trenches or other excavations shall be removed by pumping or by other approved methods.

B. Trench Excavation: Trenches shall be excavated to the width and depth as necessary to lay the pipe to the grade line as indicated on the Plans with proper pipe embedment. The Contractor shall perform excavation of materials encountered in accordance with Section 2102.3, regardless of material type, to the depths indicated on the drawings or as otherwise specified herein. Excavated materials are to be deposited beside trenches and excavations to avoid overloading, and to prevent slides or cave-ins, transported to the spoil banks, or used for backfilling. All excavated materials not required or not suitable for backfill shall be removed and disposed of off the site by the Contractor as part of the Work. The trench excavation opened at one time shall be limited by the nature of the soil and other safety considerations.

1. All pipeline excavation work shall be accomplished under the supervision of a person employed by the Contractor or his subcontractor and experienced with the materials and procedures which will provide protection to existing improvements, including utilities and the proposed pipeline.
2. The alignment, depth, and pipe subgrades of all trenches shall be determined by a laser beam parallel to the pipe invert.
3. Deviation from the indicated alignment will not be permitted except under special circumstances, subject to approval of the Engineer.
4. Trenches that are parallel to structures, pavements or walls shall be no closer than 18 inches from the closest edge of footings or pavement. Also, no parallel trench shall extend in depth below a plane having a downward slope of 1 horizontal to 2 vertical starting from a line 9 inches above the bottom edge of footings or pavement. The bottom of pavement shall be the lowest improved section of pavement to include chemically stabilized subgrade or aggregate base layers.
5. When pipe is to be installed in embankment or fill, the embankment shall be constructed in accordance

with APWA section 2102.6 and shall be built up to a plane at least 18 inches above the top of the pipe prior to the excavation of the pipe trench.

6. The Contractor shall not open more trench in advance of pipe laying than is necessary. Four hundred (400) feet will be the maximum length of open trench allowed on any line under construction. All open trenches shall be adequately protected.
 7. Undercutting of trench walls is not permitted.
 8. Option to Trenching: Contractor may perform excavation by tunneling methods as set forth herein at no additional cost to the Owner provided prior written approval for each such location is obtained from the Engineer. The Contractor shall submit to the Engineer, prior to actual work, a written description of his proposed operation. It shall include the types and locations of shafts, methods to provide safe support strength for the pipeline when the shafts or bore pits exceed maximum allowable trench widths and other features that would affect the pipeline. Tunneling shall be done with a minimum inconvenience and disturbance to the general public and abutting property owners.
- C.** Trench Widths: Trenches shall be excavated to a width that will provide adequate working space and pipe clearances for proper pipe installation, jointing, and embedment. Over-excavation shall be replaced with granular bedding material or flowable backfill (CLSM). See applicable Plans, Standard Drawings, and manufacturers' recommendations for trench widths for pipe installations.
- D.** Preparation of Pipe Subgrade: Pipe subgrade shall be prepared to provide uniform and continuous support of pipe. The trench bottom shall be evenly graded. Areas that are too high shall be shaved as required. Any portions of the trench that are found to be too low shall be filled with suitable materials, thoroughly compacted, and brought to true grade, allowing for placement of bedding material as shown in the Standard Drawings.
- E.** Trench Bottom in Rock Excavation: Where rock is encountered in excavation, the rock shall be removed to provide a minimum clearance of 6 inches below and 6 inches along each side of the pipe.
- F.** Replacement of Unsuitable Pipe Foundation Material
1. If unstable subgrade conditions are encountered and it is determined by the Engineer that the excavation bottom will not provide suitable support, the Contractor shall remove all unstable or unsuitable material over the entire width of the trench to the depth required by the Engineer to provide a stable foundation. Removal shall not be less than 6 inches.
 2. Materials so removed shall be replaced with bedding aggregate material as specified herein. Bedding material shall be mechanically compacted over the entire width of the trench and shall be brought to proper grade, shape, and elevation for the installation of the pipe as shown on the Plans or Standard Drawings.
- G.** Granular Bedding Materials: Granular bedding material shall meet ASTM C33 with one of the following gradation requirements:

Sanitary Sewer Bedding Material Gradation Limits (% Passing)	
Sieve Size	3/4"
1"	100
3/4"	90 – 100
3/8"	20 – 55
No. 4	0 – 5
No. 8	0 – 2

Storm Sewer Bedding Material Gradation Limits (% Passing)			
Sieve Size	3/4"	1/2"	3/8"
1"	100		
3/4"	90 – 100	100	
1/2"		80 – 100	
3/8"	20 – 55	40 – 77	100
No. 4	0 – 10	0 – 15	30 – 40
No. 8	0 – 5	0 – 5	0 – 4

Waterline Bedding Material Gradation (% Passing)				
Sieve Size	Type 1 (1/2")	Type 2 (Buckshot)	Type 3 (Man. Sand)	Type 4 (River Sand)
3/4"	95 – 100			
3/8"	40 – 60	100	100	
1/4"			90 – 100	
No. 4		60 – 80	85 – 90	100
No. 8	0 – 5	0 – 15	35 – 75	
No. 50			10 – 25	
No. 200		0	0 – 10	0 – 10

- H. Pipe Embedment: All water, sanitary sewer, and storm sewer pipe shall be bedded in bedding aggregate as specified herein.
1. Bedding shall cover the entire width of trench.
 2. The first layer of bedding placed on the bottom of excavation shall be in accordance with Figures 1 through 3.
 3. Bedding at bottom of trench, in the middle 1/3 of trench under the pipe shall be loose.
 4. After pipe is placed, bedding material shall be placed in layers in accordance with manufacturer's recommendations.
 5. Second layer of bedding material shall be placed under the lower haunches of the pipe up to the springline (center of pipe). Material shall be spaded to be placed under haunches and compacted at the springline elevation prior to placing additional bedding material.
 6. The third layer of bedding material shall be placed to 12 inches over the top of pipe.
 7. Contractor shall take measures to prevent pipe from floating during placement of bedding material so that pipe maintains proper line and grade as shown on the Plans.

I. Trench Backfill

1. Backfill shall not be placed when material contains frost, is frozen, or a blanket of snow prevents proper compaction.
2. The Contractor shall remove from the project site waste material, trees, organic material, rubbish, or other deleterious materials.
3. All trash and debris shall be removed from the pipeline excavation prior to backfilling.
4. Backfill material shall be carefully placed to avoid damage to or displacement of the pipe, other utilities or structures.
5. Unless otherwise specified, all trenches and excavations around structures shall be backfilled to the original ground surface.
6. Outside of paved areas, the backfill material shall be placed in layers not exceeding 8-inches in loose thickness and be compacted to at least 90% of maximum density. Compaction testing shall be at the discretion of the Engineer.
7. The method of compaction and the equipment used shall be appropriate for the material to be compacted and shall not transmit damaging shocks to the pipe.
8. The combination of the thickness of the layer, the method of compaction and the type of compaction equipment used shall be at the discretion of the Contractor subject to obtaining the required densities.

J. Trench Backfilling in Street or Alley Right of Way and under Pavement

1. Narrow Trench: Suitable backfill material for trenches 24 inches or less in width and shall be flowable backfill (CLSM).
2. Standard Trench: Suitable backfill material for trenches between 24 to 48 inches wide shall be either flowable backfill (CLSM) or dense, well-graded aggregate base material. Aggregate base material shall meet the requirements for KDOT AB-3 or MoDOT Types 1 or 5.
3. Wide Trench: Suitable Backfill Material for trenches greater than 48 inches wide shall be either materials specified for standard trench or suitable material as specified for "Earth Embankment" in APWA Standard Specifications, Section 2102.2.H.
4. Suitable Backfill Material outside of paved areas within Right of Way, and all areas outside Right of Way, may be suitable material as specified for "Earth Embankment" in APWA Standard Specifications, Section 2102.2.H. Suitable Backfill Material may also be other trench backfill material (flowable backfill or aggregate base) depending on site conditions, trench widths or at the direction of the Engineer.
5. Aggregate backfill material placed between lines one foot behind curbs, or edge of uncurbed pavement, shall be meet density and testing requirements as outlined in APWA 2203 Aggregate Base Course.

6. The method of compaction and the equipment used shall be appropriate for the material to be compacted and shall not transmit damaging shocks to the pipe.
7. The combination of the thickness of the layer, the method of compaction and the type of compaction equipment used shall be at the discretion of the Contractor subject to obtaining the required densities.
8. A minimum of one compaction test shall be taken for each lift of earth embankment backfill or dense, well-graded aggregate base material for each road crossing or each 50 feet of trench length under pavement.
9. Testing shall be performed by a qualified testing lab hired by the Contractor and approved by the Owner.
10. Laboratory compaction test and index property test results for each material used on site shall be submitted to the Engineer prior to construction. Any work by Contractor prior to test submittals and subsequent Owner review and approval shall be work done at the Contractor's risk.
11. Test reports shall be submitted to the Engineer daily. The reports shall clearly indicate the location of all tests by street name, station and/or lot number, type of backfill material, utility type, and depth of test. The reports shall include the results of all tests (pass or fail) and all re-tests.
12. All test reports shall be submitted prior to receiving approval of subgrade for curb and pavement installation. Pavement, curb or other surface features placed prior to receiving subgrade approval shall be placed at the Contractor's risk.

K. Flowable Backfill (CLSM) Installation

1. Flowable Backfill (CLSM) shall be constructed to the configuration and the lines and grades shown on the Plans, or as directed by the Engineer. No additional payment will be allowed for placement beyond these limits.
2. The producer may cut back on the quantity of water incorporated during batching with the approval of the Engineer. Additional water may be added on-site to achieve the intended consistency. The final mix unit weight and compressive strength shall fall within the specified ranges as described in Section 2102.2.E.
3. No Flowable Backfill (CLSM) shall be placed on frozen ground or in standing water.
4. When the ambient temperature is either falling or forecasted to fall below 35° F within 24 hours of its proposed placement time, the Contractor may submit the use of cold weather methods for approval by the Engineer.
5. Care shall be taken to prevent the movement of any conduit, pipe or structure from the designated location or intrusion of flowable backfill into undesirable locations. If such movement or intrusion occurs, the Engineer may require the affected structure to be excavated and replaced to the proper grade at the Contractor's expense.
6. If flowable backfill is placed in more than one layer, loose and foreign material shall be removed prior to placing the next layer.

7. No flowable backfill shall be covered or accepted until a minimum compressive strength has been attained, as demonstrated by failure to deform or crush underfoot. If the flowable backfill does not harden to required strength, the flowable backfill shall be removed and replaced with an acceptable material at the Contractor's expense. Acceptance of the flowable backfill shall be based on visual inspection.
 8. Random compressive strength testing may be conducted at the Owner's expense to verify compliance with strength requirements. Compressive tests shall be in accordance with ASTM D 4832.
- L. Trench Checks**
1. Install where shown on the Plans.
 2. The backfill above the trench check shall meet the specifications for backfill material.
- M. Excavation by Tunneling or Boring:** Where depth of trench and soil conditions will allow it, tunneling may be required under pavement, railroad tracks, or other surface structures. Tunnel sections shall provide adequate clearance for pipe and workers for proper lining, grading, and jointing the pipe installed therein.
- All tunnel excavation shall provide an excavation conforming to the outside diameter of the casing and/or carrier conduit. The excavation shall be to an alignment and grade which will allow the carrier conduit to be installed to proper line and grade as shown on the Plans and as established in Section 2505.2.H. Conduct excavation in a manner to prevent disturbing overlying and adjacent material. Perform dewatering and chemical soil stabilization or grouting if necessary, due to existing field conditions.
- N. Settlement:** The Owner may perform periodic inspections to insure that no settlement has occurred. The Contractor shall be responsible for all settlement of backfill, fills and embankments which may occur within two (2) years of time after final acceptance of the contract under which the work was performed.
- The Contractor shall make, or cause to be made, all repairs or replacements made necessary by settlement within thirty (30) days after notice from the Owner. Should the Contractor fail to make such repairs the Owner may cause repairs to be made and the cost of these repairs shall be the responsibility of the Contractor.
- O. Excavation and Backfilling for Piping and Structures**
1. All structure foundations shall be founded on stable, undisturbed subgrade. Excavation shall be sufficient to provide at least 12 inches clear between the outer surfaces of the structure (including formwork) and the embankment or timber that may be used to hold and protect the excavation.
 2. Unsuitable or unstable foundation soil that will not properly support the structure, as determined by the Engineer, shall be removed to the depth required and the excavation backfilled to the proper grade with compacted bedding material or other material approved by the Engineer.
 3. All excavations for structure shall be kept dry; no reinforcing steel shall be installed in water; and no water shall be permitted to inundate the reinforcing steel before concrete has been placed.
 4. Street Right-of-Way Areas: All structures located under or within paved or graveled areas shall be backfilled with flowable backfill (CLSM) to a level flush with the top of pavement subgrade. Structures located under or within vegetated areas shall be backfilled with flowable backfill (CLSM) to a level

twelve inches below finish grade and consolidated topsoil. The external opening surfaces of weep holes shall be covered with hardware cloth and surrounded with a minimum of three cubic feet of consolidated granular bedding material.

5. Areas other than Street Right of Way: All structures located under or within paved or graveled areas shall be backfilled with flowable backfill (CLSM) to a level flush with the top of pavement subgrade. Structures located under or within vegetated areas shall be backfilled with CLSM, untreated compacted aggregate, consolidated granular bedding material, or compacted soil to a level twelve inches below finish grade. The external opening surfaces of weep holes shall be covered with hardware cloth and surrounded with a minimum of three cubic feet of consolidated granular bedding material. The top twelve inches shall be backfilled with topsoil.
6. Backfilling
 - a. No backfill shall be placed over or around any structure until the concrete or mortar therein has attained a minimum strength of 2000 psi and can sufficiently support the loads imposed by the backfill without damage.
 - b. The Contractor shall use utmost care to avoid any wedging action between the side of the excavation and the structure that would cause any movement or floating of the structure. Any damage caused by premature backfill or by the use of equipment on or near a structure will be the responsibility of the Contractor.
 - c. Backfill shall be placed and compacted on all sides of the structure simultaneously, and operations shall be so conducted that the backfill is always at approximately the same elevation on all sides of the structure.
 - d. No excavated rock larger than 3 inches maximum dimension shall be placed within 1 foot of the exterior surface of any structure except as allowed with flowable backfill (CLSM) placement.
 - e. No backfill material containing rock, or detritus from rock excavation, shall be placed in the upper 24 inches of the excavation.
 - f. Large rock may be placed in the remainder of the backfill upon approval of the Engineer. Approved rock material shall be placed so that it is well separated, allowing proper compaction of soil backfill around the rock material.
 - g. All excavation shall be backfilled to the lines and grades shown on the Plans.
 - h. After the required curing time, backfill shall be placed and compacted in layers. Contactor shall monitor impact of placement, vibration and related work so not to damage or disturb structures.
 - i. Backfill shall be place in compacted in layers not exceeding 8-inches in loose thickness and be compacted to at least 95% of maximum density at optimum moisture \pm 3% as determined by ASTM D 698. Each lift shall be compacted and tested to the required density prior to the next lift being placed. Testing shall be performed by a qualified testing lab hired by the Contractor and approved by the Owner.
 - j. In no instance shall backfill be dumped, bulldozed, or otherwise deposited in bulk upon the newly constructed structure.

P. Backfill of Drainage Course Crossings

1. Excavation in rock to a distance of 10 feet beyond each bank (measured perpendicularly to the stream flow) shall be backfilled with concrete to the existing rock elevation. The excavation above the rock elevation shall be backfilled with soil above that concrete encasement or as indicated on the Plans.

The soil placed above the encasement shall be compacted to at least 95% of maximum density at optimum moisture \pm 3% as determined by ASTM D 698.

2. Pipe placed in an excavation in soil shall be encased in concrete to a minimum of 1 foot above and below the pipe and backfilled with soil above that concrete encasement or as indicated on the Plans. The soil placed above the encasement shall be compacted to at least 95% of maximum density at optimum moisture \pm 3% as determined by ASTM D 698.

2102.5 Undergrading

- A. Where materials are encountered which are deemed as unsuitable by the Engineer for use in the work, they shall be removed to the depth and limit as ordered by the Engineer. Areas undergraded shall be backfilled with one of the following materials:
 1. Replacement with suitable materials from excavation on the work site or from an off-site borrow area, compacted to the required moisture and density requirements where practicable.
 2. Mixing of stone base or rock materials, hydrated lime, portland cement or fly ash into the sub-grade.
 3. Placement of compacted aggregate.
 4. Rock fragments or spalls. A granular type material having a plasticity index not to exceed 10 and a gradation such that at least 50 percent of the material will be retained on the No. 4 Sieve and not more than 40 percent will pass the No. 10 Sieve.
 5. A material meeting the requirements of Section 2102.2.H.2.

2102.6 Embankment

- A. This section governs embankment for all improvements. The embankments shall be constructed using suitable materials, as herein defined, procured from excavations made on the project site or from borrow areas as required to complete the grading work.
- B. Starting the Embankment: Where embankments, regardless of height, are placed against hillsides or existing embankments, either of which have a slope steeper than 1 vertical to 4 horizontal, the existing slope shall be benched or stepped in approximately 24 inch rises as the new fill is brought up in 8 inch maximum layers or lifts. The material bladed out, the bottom of the area cut into, and the embankment material being placed, shall be compacted to the required density. Material cut out, bladed into place and compacted shall not be measured and paid for directly but will be considered as incidental work.

The existing surface upon which embankment material is to be placed shall have all unstable and unsuitable material removed before starting the embankment work. Where embankments 2 feet or less in depth are to be placed on areas covered by existing pavement, the existing pavement shall be removed and the cleared ground surface shall be compacted to the specified density. Where embankments greater than 2 feet in depth are to be placed on areas covered by existing pavement, the existing pavement shall be broken into pieces no larger than 18 inches maximum dimension, left in place and the embankment started thereon.

- C. Placing Earth Embankment: Earth shall be placed in successive horizontal layers distributed uniformly over the full width of the embankment area. Each layer of material shall not exceed 8 inches maximum in thickness

(loose state) and shall be compacted to not less than the required density before the next layer is placed thereon. As the compaction of each layer progresses, continuous blading, or dozing will be required to level the surface and to ensure uniform compaction. Embankment construction shall not be performed when material contains frost, is frozen or is snow covered.

- D.** Placing Earth and Rock Embankment: When earth and stone or rock fragments are mixed in the embankment, all stones or rock fragments exceeding the thickness of the compacted lift shall be disposed of by being incorporated into the embankment outside the limit of the proposed paved areas. The thickness of the layer in these areas may be increased if necessary to accommodate the rocks, but shall not exceed 12 inches in thickness (loose state). The stones or rock fragments are to be placed so there will be no nesting.
- E.** Consolidated Rock Embankment: When the excavated material consists predominantly of stone or rock fragments of such size that the material cannot be placed in layers of the thickness prescribed, such material shall be placed in the embankment in layers having a thickness of the approximate average size of the larger rocks but not to exceed 24 inches. Rocks or boulders too large to permit placing in a 24 inch layer shall be reduced in size as necessary to permit placement. Rock shall not be dumped in place but shall be distributed by blading or dozing in a manner to insure proper placement in final position in the embankment. Voids shall be filled with smaller stones, earth, sand, or gravel. Each layer shall be thoroughly consolidated before the next layer is placed.

Rock embankment shall be capped with 3 feet of soil material on all sides. The soil cap material shall not contain material having a maximum dimension greater than 3 inches.

- F.** Compacting the Embankment: Before placing any embankment, the surface of the existing ground shall be prepared as specified herein, moistened as required, and the top 6 inches compacted to a density of 90 percent as prescribed by the following paragraph:

All embankment shall be compacted to a density of at least 90 percent of the maximum density for the material used as determined by ASTM D 698 with a moisture range sufficient to allow for proper compaction. In addition to the above required compaction, the subgrade between lines 1 foot outside of the curbs and within the top 6 inches of the subgrade in cut sections and the top 18 inches in fill sections shall be compacted to a density of at least 95 percent of the maximum density for material used as determined by ASTM D 698 and with a tolerance of $\pm 3\%$ of the optimum moisture at maximum density.

All work involved in either adding moisture to or removing moisture from embankment materials to within these moisture limits shall be considered incidental to the completion of the grading operation.

- G.** Moisture – Density Determination: In-place density and moisture content of the embankment will be determined by an acceptable method as approved by the Engineer.

H. Testing

1. Laboratory compaction test and index property test results for each material used on site shall be submitted to the Engineer prior to placement. Any work by Contractor prior to test submittals and subsequent Engineer review and approval shall be work done at the Contractor's risk.
2. In-Place Density/Moisture tests shall be taken at the frequency of 4 per day per spread, with a minimum of one test per lift.
3. Test reports shall be submitted to the Engineer daily. The reports shall clearly indicate the location of

all tests by street name, station and/or lot number, type of material, and elevation of test. The reports shall include the results of all tests (pass or fail) and all re-tests.

4. All test reports shall be submitted prior to receiving approval of subgrade for subsequent work. Pavement, curb, other surface features or utilities placed prior to receiving embankment approval shall be placed at the Contractor's risk.
- I. Backfilling Curb and Gutter: Backfilling behind curb or curb and gutter shall be done within seven (7) days after being laid unless otherwise approved by the Engineer. The material used to fill the void behind curb or curb and gutter shall be free of rock and debris and shall be of a type that will leave no voids to pocket water. Unless otherwise shown on the contract drawings, the finish grading from the back of the curb to the right-of-way line and/or utility easement line or construction easement line shall be performed to provide a smooth transition between existing yard grades at the right-of-way line and/or easement line to the curb so that positive drainage will exist.

The top portion of the backfill within right-of-way areas shall be finished with at least 6 inches of topsoil corresponding to, or better than, that underlying adjoining sodded areas. Topsoil shall be approved by the Engineer prior to placement, and unless otherwise directed, shall be material previously excavated and stockpiled for the purpose during excavating and grading operations. Immediately prior to dumping and spreading topsoil, the surface shall be loosened by discing or scarifying to a minimum depth of two (2) inches to permit bonding of the topsoil to the underlying surface.

2102.7 Finishing

- A. In areas where sodding or seeding is proposed, the upper 12 inches of the surface area shall be earth material free of rocks greater than 1 inch in diameter. The top 6 inches shall be topsoil suitable for sustaining grass or sod.
- B. Except where other permit or utility work is in progress, the graded surface shall be made free of rock, concrete, and brick, or fragments thereof, or rubbish and shall be finished to the lines, grades, and cross-section indicated on the Plans, including shoulder, berm and sidewalk spaces.
- C. The Contractor shall repair any damaged surface, and shall not use any finishing equipment that will leave a marred surface. When the subgrade preparation is included as a part of the finishing, the work shall be accomplished according to the requirements of Section 2201 entitled "Subgrade Preparation", and shall be considered incidental to finishing the grading work.

2102.8 Cleanup

Cleanup shall follow the work progressively and final clean-up shall follow immediately behind the finishing. The Contractor shall remove from the site of the work all equipment, tools and discarded materials, and other construction items. The entire right-of-way or easement shall be left in a finished and neat condition. Cleanup shall be considered as incidental to the completion of grading work.

SECTION 2103 MEASUREMENT AND PAYMENT

2103.1 General

There will be no measurement or separate payment for any items of work not specifically identified and listed in the Contract Documents and all costs will be included in the contract unit prices for other items listed in the Contract Documents.

2103.2 Method of Measurement

The quantities of accepted work will be measured and determined as follows:

A. Clearing, Grubbing, and Demolition

1. Clearing may be listed in the Contract Documents and measured per acre or hundredth part thereof.
2. Grubbing may be listed in the Contract Documents and measured per acre or hundredth part thereof.
3. Demolition may be included as Clearing or may be listed in the Contract Documents as a separate item and measured per each and as such shall include all work as defined in Section 2101.2.D.
4. Tree removal may be included in Clearing or may be listed as a separate item in the Contract Documents and measured per each.
5. Brush removal shall not be measured and will be subsidiary to other items in the Contract Documents.

B. Grading

1. Unclassified Excavation may be listed in the Contract Documents and measured to determine the quantity in cubic yards or tenth part thereof.
2. Rock Excavation may be included as Unclassified Excavation or may be listed in the Contract Documents as a separate item and measured to determine the quantity in cubic yards or tenth part thereof. No measurement will be made for rock overbreak in excess of 12 inches below the subgrade elevation.
3. Earth Excavation may be included as Unclassified Excavation or may be listed in the Contract Documents as a separate item and measured to determine the quantity in cubic yards or tenth part thereof. No measurement will be made for embankment performed in rock overbreak areas, where the overbreak is in excess of 12 inches below the subgrade elevation.
4. Embankment may be listed in the Contract Documents and measured to determine the quantity in cubic yards or tenth part thereof.
5. Undergrading may be listed in the Contract Documents and measured to determine the quantity in cubic yards or tenth part thereof.

C. Excavation for pipelines, utilities and all other underground facilities is subsidiary to the pay item for the pipeline, utility or specific underground facility.

D. Testing required by the Contractor shall be subsidiary to other items of the Contract Documents. No separate payment will be made.

2103.3 Basis of Payment

Payment for the quantities of accepted work will be made as follows:

A. Clearing, Grubbing, and Demolition

1. Clearing, grubbing, or clearing and grubbing may be included in the Contract Documents as separate items or as one item and will be paid for by one of the following:
 - a. Payment will be made at the contract unit bid price.
 - b. Payment will be made at the contract lump sum bid price.
2. Demolition, if listed as a separate item in the Contract Documents and not included as a part of Clearing, or Clearing and Grubbing will be paid for by one of the following:
 - a. Payment will be made at the contract unit bid price.
 - b. Payment will be made at the contract lump sum bid price.
3. Site Preparation, if listed in the Contract Documents as a separate item and not included as a part of Clearing, or Clearing and Grubbing will be paid for by one of the following:
 - a. Payment will be made at the contract unit bid price.
 - b. Payment will be made at the contract lump sum bid price.

B. Grading

1. Unclassified Excavation, Rock Excavation, or Earth Excavation may be included in the Contract Documents as separate items or as one item and will be paid for by of the following:
 - a. Payment will be made at the contract unit bid price.
 - b. Payment will be made at the contract lump sum bid price.
2. Embankment may be included in the Contract Documents and will be paid for by one of the following:
 - a. Payment will be made at the contract unit bid price.
 - b. Payment will be made at the contract lump sum bid price.
3. Undergrading may be listed in the Contract Documents and will be paid for at the Contract unit bid price.

C. Excavation for pipelines, pipeline structures, utilities and all other underground facilities is subsidiary to the pay item for the pipeline, utility or specific underground facility.

D. Testing required by the Contractor shall be subsidiary to other items of the Contract Documents. No separate payment will be made.

SECTION 2104 BACKFILL DETAILS

Figure 1

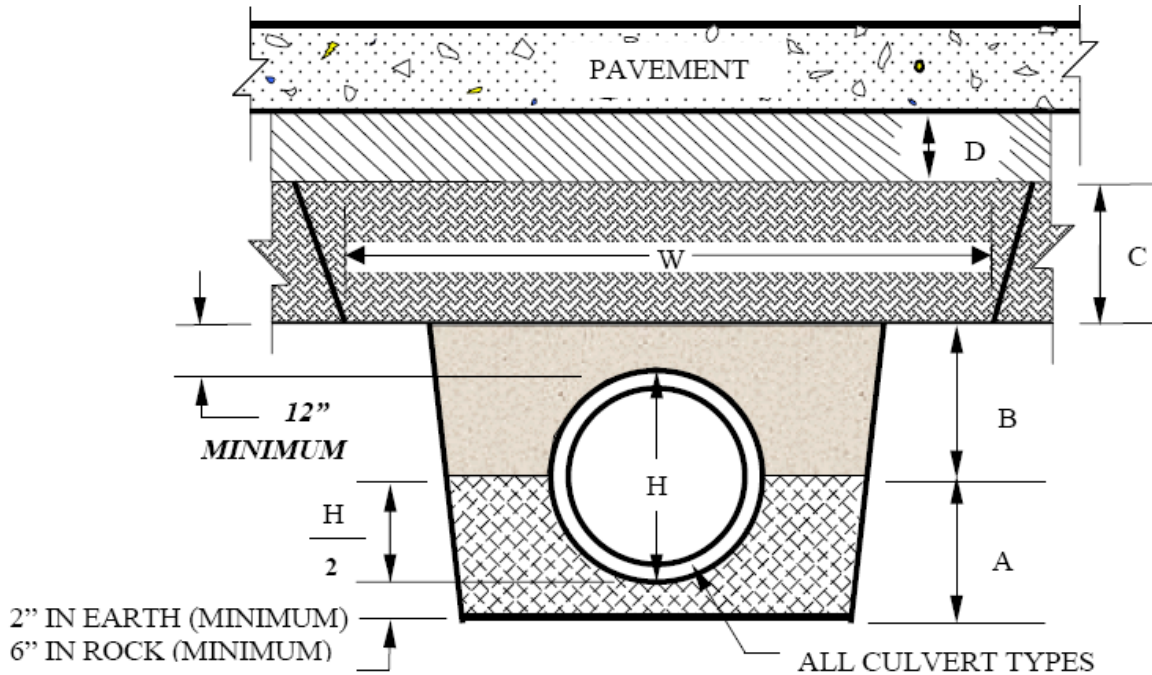

A- Consolidated granular bedding material.

B- Granular bedding material or Flowable Backfill (CLSM).

C – Compacted Embankment - 2102.6. Lift thickness shall not exceed the capability of the equipment being utilized to achieve the proper density and consolidation, and in no case shall a lift exceed twelve inches for soil. The minimum width, W, shall be two feet wider than the width of the required compaction device, or five feet, whichever is greater.

D – Compacted Subgrade - Subgrade thickness shall be as specified in Table 1 of Section 5206 and as directed by the Engineer. Subgrade preparation shall be done in accordance with Section 2201 and shall consist of aggregate for base course, stabilized subgrade, or compacted soil – in accordance with the associated Sections 2201, 2202, and 2203.

Figure 1
(Deep Sewer Lines Using Earth Compaction Equipment,
or in Depths Exceeding 30" of Cover)

Figure 2

The following cross-sectional view of typical storm sewer trench construction under street, alley pavements, and entrances Figure 2, shall apply to all storm sewer backfill areas where deep trenches are not widened to allow heavy roadway compaction equipment. Figure 2 shall also apply to shallow (30" to 18" from top of pipe to bottom of pavement) roadway trenches:

Backfilling shall be placed as shown in Figure 2.

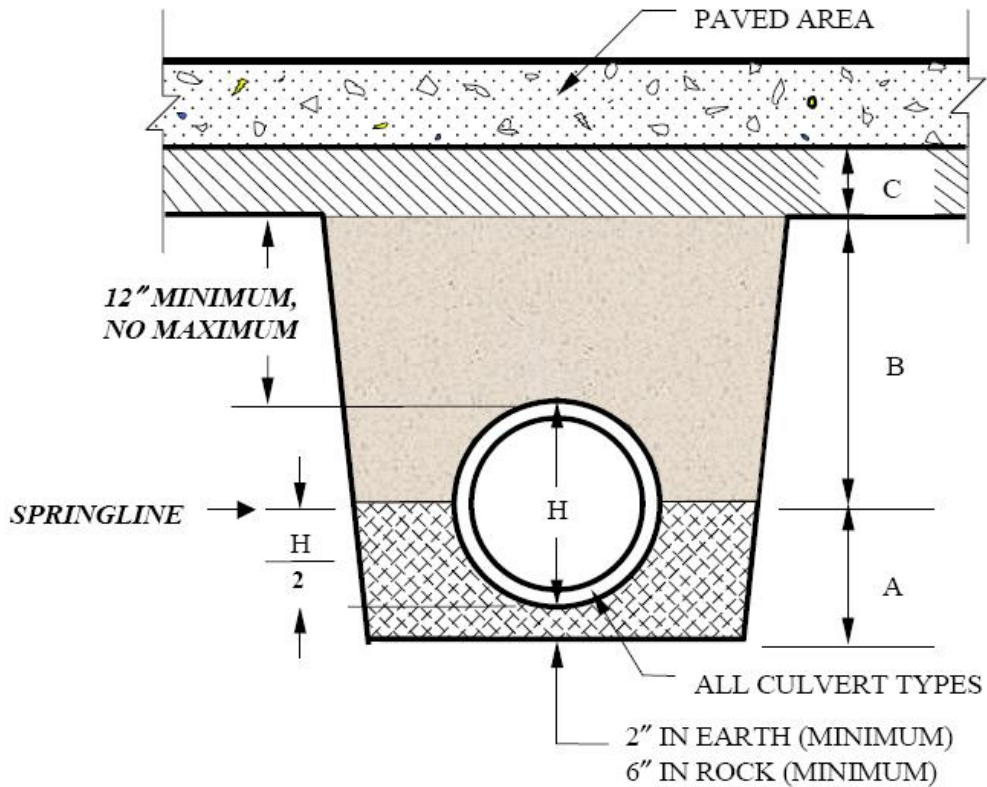

A- Consolidated granular bedding material.

B- Granular bedding material, hand compacted soil - 95% of max. density using ASTM D 698, or Flowable Backfill (CLSM). Maximum lift thickness 6". Granular bedding material shall be used in Zone B for all pipe except reinforced concrete pipe.

C – Compacted Subgrade - Subgrade thickness shall be as specified in Table 1 of Section 5206 and as directed by the Engineer. Subgrade preparation shall be done in accordance with Section 2201 and shall consist of aggregate for base course, stabilized subgrade, or compacted soil – in accordance with the associated Sections 2201, 2202, and 2203.

Figure 2
(For Deep Trenches Without Roadway Compaction Equipment,
or Shallow Trenches Having Less than 30" of Cover)

Figure 3

Trench backfilling in areas other than street and alley pavements where the near edge of trench is behind the back of curb:

Backfilling shall be placed as shown in Figure 3.

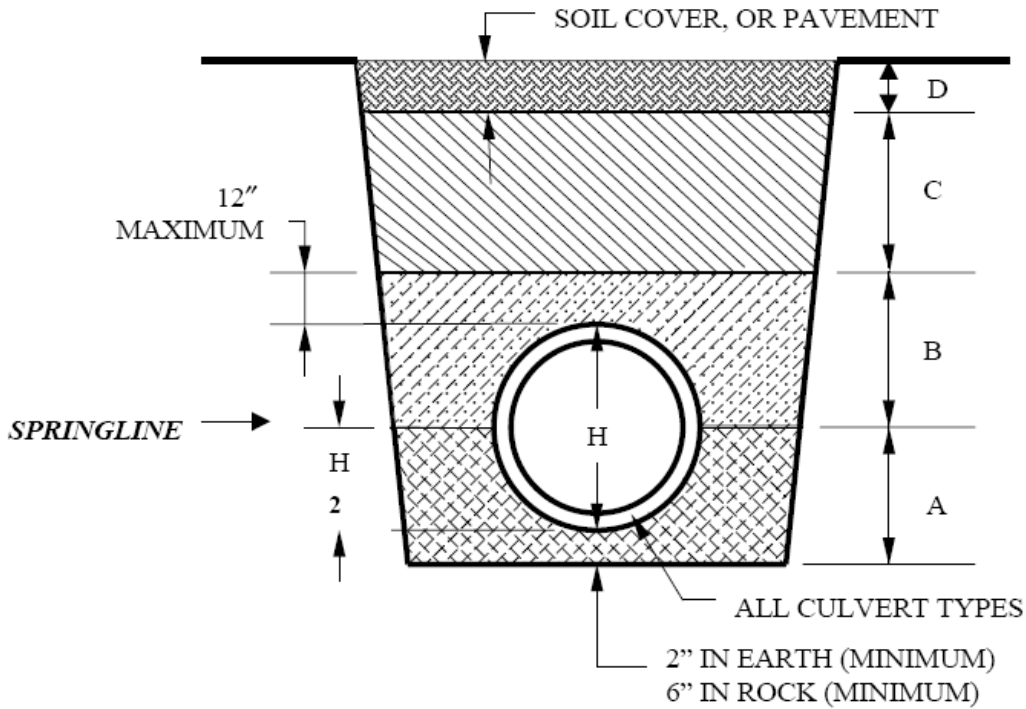

A – Consolidated granular bedding material.

B – Consolidated granular bedding material, flowable backfill (CLSM), or compacted soil – compacted to 90% of maximum density using ASTM D 698. Maximum lift thickness for the granular or soil materials shall be six inches.

C – Consolidated granular bedding material, flowable backfill (CLSM), or compacted soil – compact to approximate density of adjacent soil but not less than 90% of maximum density using ASTM D 698. Lift thickness shall not exceed the capability of the equipment being utilized to achieve the proper density and consolidation; however, in no case shall it exceed six inches for soil.

D – Soil Cover – Soil cover shall be as specified in Section 2102.7. The top twelve inches shall be consolidated soil; the top six inches shall be topsoil suitable for sustaining grass.

**Figure 3
(Trenches Outside of Street Pavements)**

Figure 4

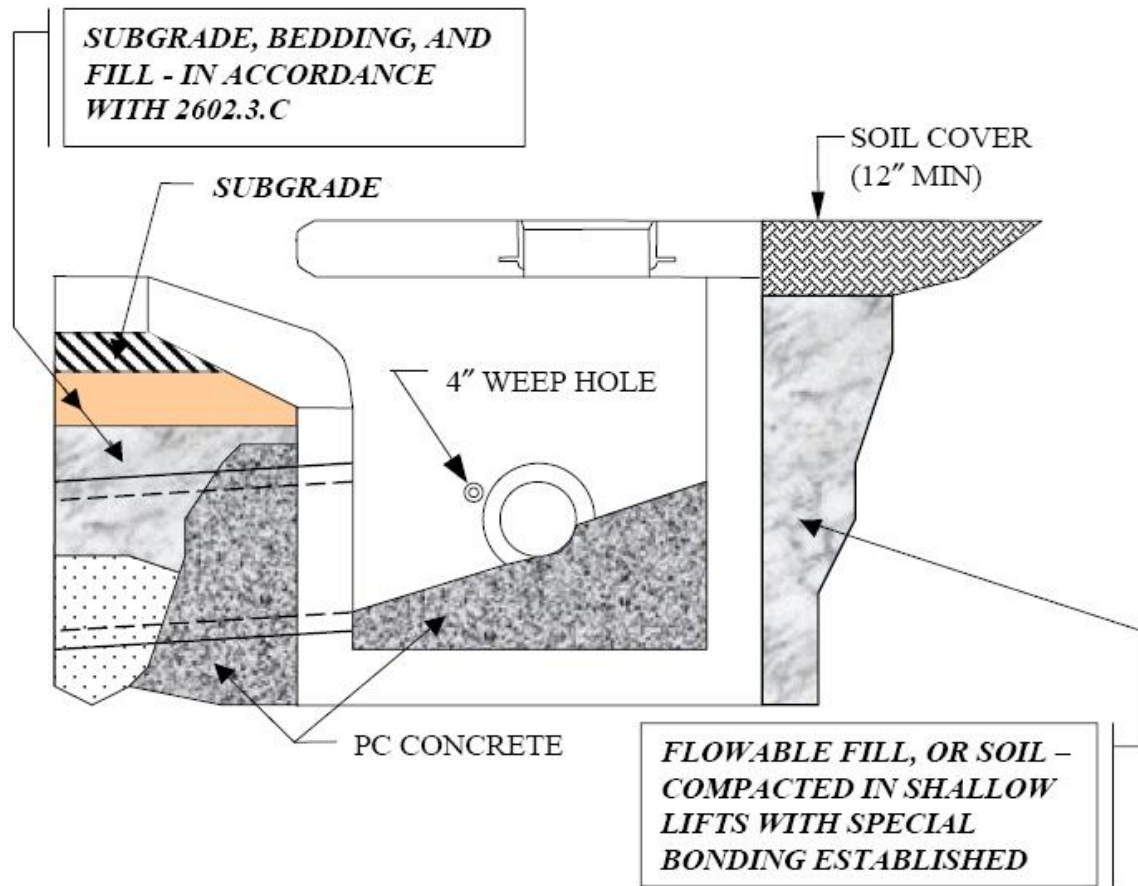

Note: Weep hole shall be backed by filter fabric or hardware cloth, and 3 cubic feet of granular material.

FIGURE 4
(Structures Adjacent to Street Pavements)